

**Universal Mobile Telecommunications System (UMTS);
Selection procedures for the choice of radio transmission
technologies of the UMTS
(UMTS 30.03 version 3.2.0)**

UMTS

Universal Mobile
Telecommunications System



European Telecommunications Standards Institute

Reference

RTR/SMG-023003UR1 (aao01ic4.PDF)

Keywords

ETSI, SMG-5, Selection of radio transmission technology, radio interface, UMTS

ETSI Secretariat

Postal address

F-06921 Sophia Antipolis Cedex - FRANCE

Office address

650 Route des Lucioles - Sophia Antipolis
Valbonne - FRANCE
Tel.: +33 4 92 94 42 00 Fax: +33 4 93 65 47 16
Siret N° 348 623 562 00017 - NAF 742 C
Association à but non lucratif enregistrée à la
Sous-Préfecture de Grasse (06) N° 7803/88

Internet

secretariat@etsi.fr
<http://www.etsi.fr>
<http://www.etsi.org>

Copyright Notification

No part may be reproduced except as authorized by written permission.
The copyright and the foregoing restriction extend to reproduction in all media.

Contents

Intellectual Property Rights.....	5
Foreword	5
Introduction	6
1 Scope.....	7
2 References.....	7
3 Abbreviations and definitions	7
3.1 Abbreviations.....	7
3.2 Definitions	8
4 Structure of the Recommendation.....	8
5 Radio Transmission Technology considerations	8
5.1 Radio transmission technologies functional blocks.....	10
5.1.1 Multiple access technology	10
5.1.2 Modulation technology.....	10
5.1.3 Channel coding and interleaving	10
5.1.4 Duplexing technology	11
5.1.5 Physical channel structure and multiplexing	11
5.1.6 Frame structure.....	11
5.1.7 RF channel parameters	11
5.2 Other functional blocks.....	11
5.2.1 Source coder.....	11
5.2.2 Interworking.....	11
6 Technical characteristics chosen for evaluation	11
6.1 Criteria for evaluation of radio transmission technologies.....	12
6.1.1 Spectrum efficiency.....	12
6.1.2 Technology complexity - effect on cost of installation and operation.....	12
6.1.3 Quality.....	12
6.1.4 Flexibility of radio technologies.....	12
6.1.5 Implication on network interface.....	13
6.1.6 Handportable performance optimization capability	13
6.1.7 Coverage/Power efficiency	13
7 Selected test environments for evaluation	14
8 Evaluation methodology	14
8.1 Objective criteria	14
8.2 Subjective criteria	15
8.3 Evaluation spreadsheet.....	15
8.4 Summary evaluations.....	15
Annex A: Technologies description template.....	16
Annex B: Test environments and deployment models.....	31
B.1 Test Environments	31
B.1.1 Mapping of high level requirements onto Test environments	31
B.1.2 Services description	32
B.1.2.1 Test services characteristics	32
B.1.2.2 Traffic models	33
B.1.2.3 Tests configurations	36
B.1.3 Test Environment Descriptions.....	38
B.1.3.1 Indoor Office Test Environment	38
B.1.3.2 Outdoor to Indoor and Pedestrian Test Environment.....	38
B.1.3.3 Vehicular Test Environment.....	39

B.1.3.4	Mixed Test Environment.....	39
B.1.4	Propagation Models	39
B.1.4.1	Path Loss Models	39
B.1.4.1.1	Path Loss Model for Indoor Office Test Environment	40
B.1.4.1.2	Path Loss Model for Outdoor to Indoor and Pedestrian Test Environment.....	40
B.1.4.1.3	Path Loss Model for Vehicular Test Environment	41
B.1.4.1.4	Decorrelation Length of the Long-term Fading	41
B.1.4.2	Channel Impulse Response Model	42
B.1.5	Antenna patterns for sectorisation.....	43
B.1.6	Link Budget Template and Deployment Models	44
B.1.6.1	Terrestrial Link Budget Templates.....	45
B.1.6.2	Low traffic levels for coverage efficiency evaluation.....	48
B.1.6.3	Proposed methodology for coverage efficiency evaluation.....	49
B.1.6.4	Deployment Model.....	49
B.1.6.4.1	Indoor Office Test Environment Deployment Model	50
B.1.6.4.2	Outdoor To Indoor and Pedestrian Deployment Model	52
B.1.6.4.3	Vehicular Environment Deployment Model	54
B.1.6.4.4	Mixed-cell Pedestrian/Vehicular Test Environment Deployment Model	55
B.1.6.5	Spectrum efficiency evaluation	56
B.1.6.5.1	Active Session Throughput.....	56
B.1.6.5.2	Satisfied user	56
B.1.6.5.3	System Load	57
B.1.6.5.4	Spectrum Efficiency	57
B.1.6.5.5	Parameter values.....	58
B.1.6.5.6	Required results	58
B.1.6.6	Deployment Model Result Matrix.....	59
B.1.7	Guard band evaluation	59
B.1.7.1	Scenarios for guard band evaluation	59
B.1.7.2	Evaluation methodology.....	60
B.1.7.3	System parameters.....	61
B.1.7.4	Presentation of results	62
B.1.8	Propagation Models	62
B.1.8.1	Path Loss Models	62
B.1.8.1.1	Path Loss Model for Indoor Office Test Environment	62
B.1.8.1.2	Path Loss Model for Outdoor to Indoor and Pedestrian Test Environment.....	63
B.1.8.1.3	Path Loss Model for Vehicular Test Environment	64
B.1.8.2	Channel Impulse Response Model	65
Annex C:	Detailed Evaluation Procedures.....	67
C.1	Introduction.....	67
Annex D:	Guidance on Simulations	81
D.1	Introduction.....	81
D.2	TDD working assumptions	81
D.2.1	Circuit Switched Data Services.....	81
D.2.2	Spectrum efficiency	81
D.2.3	Coverage Efficiency - Bit Error Rate.....	81
D.3	Finite Area Simulations	81
D.4	Decorrelation of Long Term fading - correct interpretation.....	81
Annex E:	Document change history.....	83
History	84

Intellectual Property Rights

IPRs essential or potentially essential to the present document may have been declared to ETSI. The information pertaining to these essential IPRs, if any, is publicly available for **ETSI members and non-members**, and can be found in ETR 314: "*Intellectual Property Rights (IPRs); Essential, or potentially Essential, IPRs notified to ETSI in respect of ETSI standards*", which is available **free of charge** from the ETSI Secretariat. Latest updates are available on the ETSI Web server (<http://www.etsi.fr/ipr>).

Pursuant to the ETSI Interim IPR Policy, no investigation, including IPR searches, has been carried out by ETSI. No guarantee can be given as to the existence of other IPRs not referenced in ETR 314 (or the updates on <http://www.etsi.fr/ipr>) which are, or may be, or may become, essential to the present document.

Foreword

This ETSI Technical Report has been produced by the Special Mobile Group (SMG) of the European Telecommunications Standards Institute (ETSI).

The contents of this TR is subject to continuing work within SMG and may change following formal SMG approval. Should SMG modify the contents of this TR, it will be republished by ETSI with an identifying change of release date and an increase in version number as follows:

Version 3.x.y

where:

- y the third digit is incremented when editorial only changes have been incorporated in the specification;
- x the second digit is incremented for all other types of changes, i.e. technical enhancements, corrections, updates, etc.

Introduction

This ETSI Technical Report (TR) lists the criteria and the procedures which are to be used to compare and evaluate various candidates for the physical radio transmission technology of UMTS. The physical radio transmission technology is defined as the parts handling the bearers, normally described as a part of OSI layer 1-3. Channel coding and interleaving may therefore be included. The quality criteria does not include the quality of service for different services.

The evaluation procedure in this document is based on the REVAL evaluation guidelines defined in ITU-R [2]. Wherever the procedure defined here deviates from ITU-R [2] it is indicated separately.

1 Scope

This ETSI Technical Report (TR) establishes the technical procedure for the comparative evaluation of candidate technologies for the UTRA. The UTRA includes the handling of the representative bearers as defined in UMTS 21.01 [1], i.e. Open System Interconnection (OSI) layers 1-3. It establishes the criteria based upon the requirements contained in UMTS 21.01 [1]. The primary purpose of this [report] is to facilitate the comparison of different candidates between milestones M1 and M2 of the UTRA definition procedure (Refinement and synthesis phase). It will also be used after milestone M2 (Definition phase) and in the submission of the candidate to ITU. The scope of this report is not to make the actual choice but to define how the technical evaluation will be performed.

2 References

This ETR incorporates by dated and undated reference, provisions from other publications. These references are cited at the appropriate places in the text and the publications are listed hereafter. For dated references, subsequent amendments to or revisions of any of these publications apply to this ETR only when incorporated in it by amendment or revision. For undated references, the latest edition of the publication referred to applies.

- [1] TS 101 111 (UMTS 21.01): "Universal Mobile Telecommunication System (UMTS); Overall requirements on the radio interface(s) of the UMTS".
- [2] Draft new Recommendation ITU-R M.[FPLMTS.REVAL] Guidelines for evaluation of radio transmission technologies for IMT-200/FPLMTS

3 Abbreviations and definitions

3.1 Abbreviations

For the purposes of this ETR the following Abbreviations apply.

ALT	Automatic Link Transfer
AWGN	Additive White Gaussian Noise
BER	Bit Error Rate
CDMA	Code Division Multiple Access
ETE	Equivalent Telephone Erlangs
FDD	Frequency Division Duplex
FDMA	Frequency Division Multiple Access
FER	Frame Error Rate
FWA	Fixed Wireless Access
GSM	Global System Mobile
LDD	Low Delay Data bearer service
LCD	Long Constrained Delay data bearer service
UDD	Unconstrained Delay Data bearer service
OSI	Open System Interconnection
RF	Radio Frequency
RMS	Root Mean Squared
SD	Standard Deviation
TDD	Time Division Duplex
TDMA	Time Division Multiple Access
UMTS	Universal Mobile Telecommunication System
WFAU	Wireless Fixed Access Unit

3.2 Definitions

For the purposes of this TR the following definitions apply.

Traffic Capacity: (Erlangs/cell (or Erlangs/satellite spot beam)) this is the total traffic that can be supported by a single cell (or spot beam), which is part of an infinite set of cells (or large number of satellite spot beams) in a uniform two-dimensional (or three dimensional) pattern. The traffic capacity must be specified at a stated spectrum allocation, quality and grade of service, assuming an appropriate propagation model. This metric is valuable for comparing systems with identical user channel requirements.

Information Capacity: (Mbits/cell (or Mbits/satellite spot beam)) this is the total number of user-channel information bits that can be supported by a single cell (or spot beam) which is part of an infinite set of cells (or large number of spot beams) in a uniform two-dimensional (or three dimensional) pattern. The information capacity must be specified at a stated spectrum allocation, quality and grade of service, assuming an appropriate propagation model. This metric is valuable for comparing systems with identical user channel requirements.

Hot Spot Capacity: Number of users who may be instantaneously supported per isolated cell (or satellite spot beam) per unit spectrum. This must be specified at a stated spectrum allocation, quality and grade of service.

Set of Radio Transmission Technologies: A complete combination of radio transmission technologies that encompass the transmission dependent functions of a radio system, which has potential capabilities to meet UMTS minimum requirements in one or more test environments.

4 Structure of the Recommendation

Clause 5 outlines the RTT considerations and identifies the transmission dependent part of the radio interface considered in the evaluation procedure. Clause 6 defines the criteria for evaluating the RTTs and clause 7 references the tests environments under which the candidate SRTTs are evaluated.

The following Annexes form part of this Recommendation:

- Annex A: Radio Transmission Technologies Description Template
- Annex B: Test Environments and Deployment Models
- Annex C: Evaluation Methodology
- Annex D: Guidance on Simulations

5 Radio Transmission Technology considerations

This clause is same as in [2].

Within a telecommunication system (see Figure 5.1), a SRTT reflects the combination of technical choices and concepts that allow for the provision of a radio sub-system. The evaluation process for candidate UMTS RTTs will involve maximising the transmission independent aspects and minimising the differences between the remaining transmission dependent parts in the various UMTS operating environments from an implementation perspective.

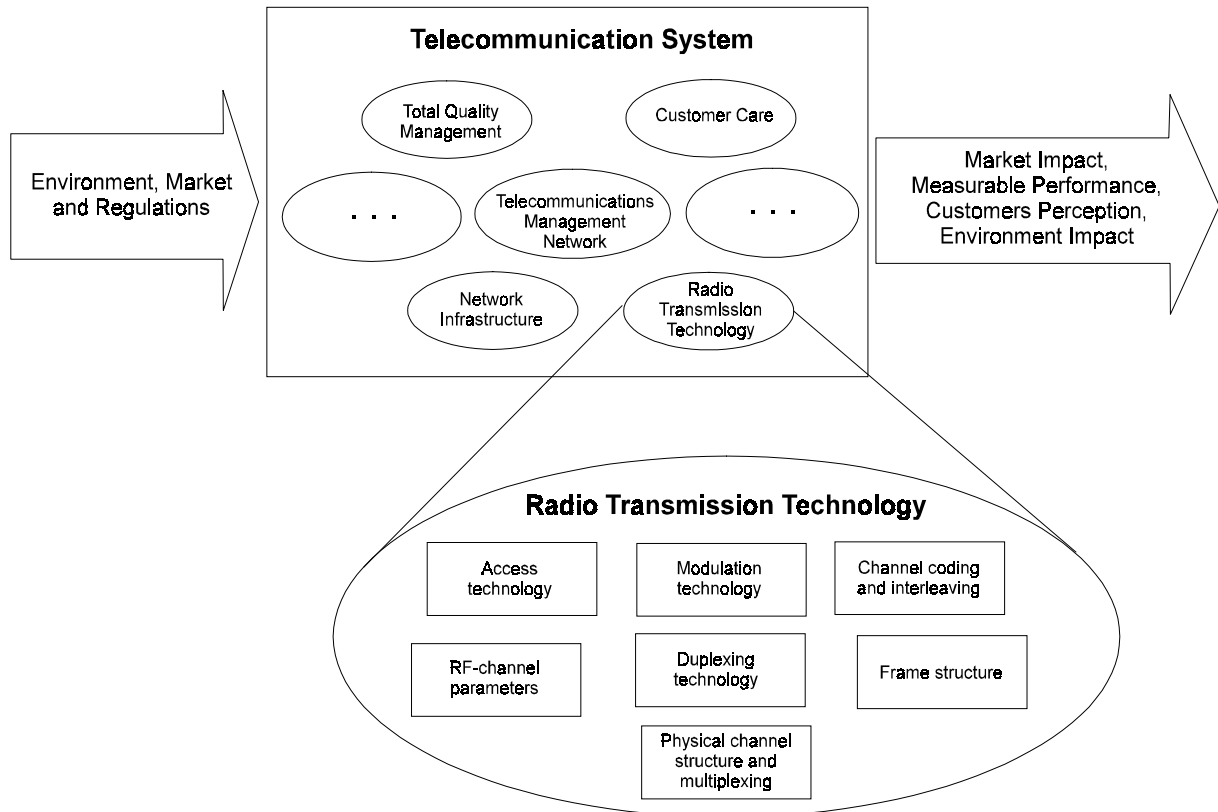

Figure 5.1: Radio Transmission Technologies as part of a total telecommunication system

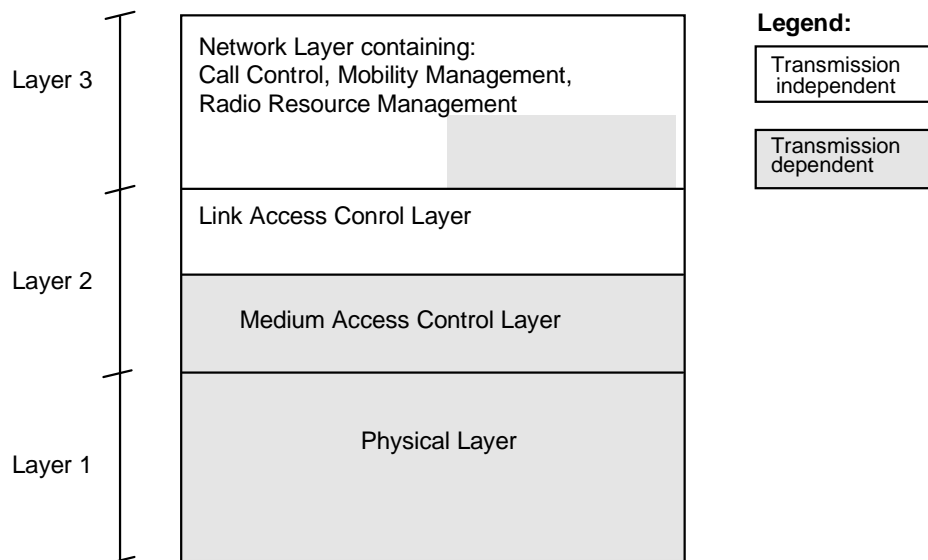

Figure 5.2: Example of a Layered Structure of Radio Interface

Figure 5.2 presents an example of a layered structure of radio interface.

As shown in Figure 5.3, the transmission dependent part of the radio interface may be considered as a set of functional blocks. It should be noted that all these functional blocks are not necessarily transmission dependent in their entirety.

The functional blocks identified here are the following:

- multiple access technology;
- modulation technology;
- channel coding and interleaving;
- RF-channel parameters such as bandwidth, allocation and channel spacing;
- duplexing technology;
- frame structure;
- physical channel structure and multiplexing.

In the process of making design choices, the dependencies between the above functional blocks have to be considered. Some of the interdependencies are shown in Figure 5.3 and are further described in section 5.1.

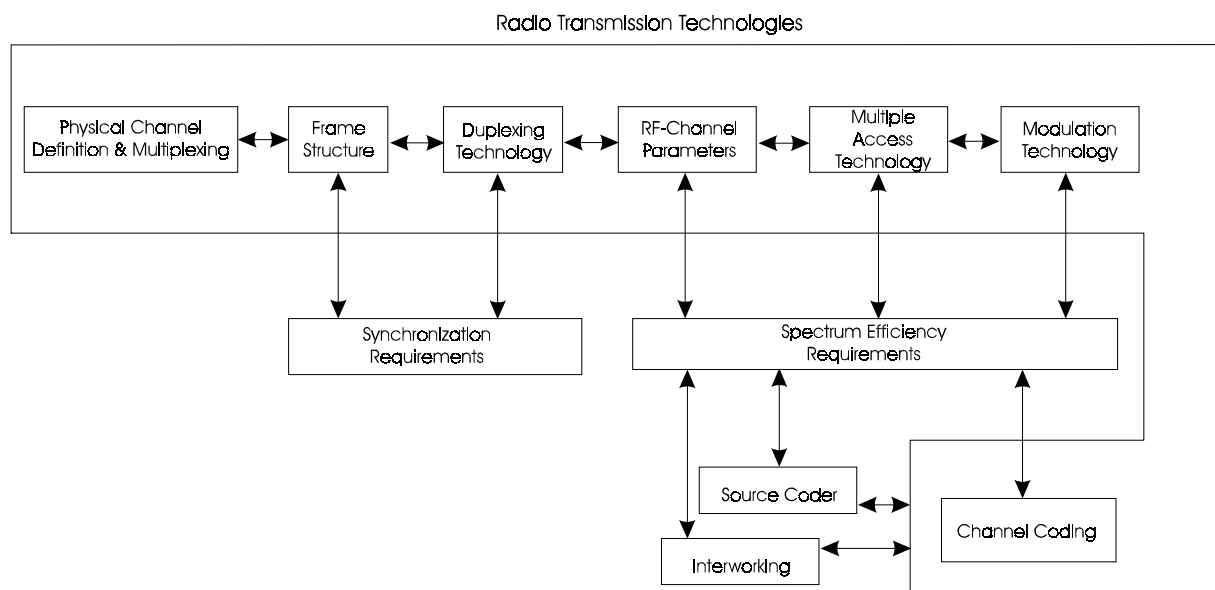

Figure 5.3: Functional Blocks and Their Interdependencies

5.1 Radio transmission technologies functional blocks

5.1.1 Multiple access technology

The choice of the multiple access technology has major impact on the design of the radio interface.

5.1.2 Modulation technology

The choice of the modulation technology depends mainly on radio environment and the spectrum efficiency requirements.

5.1.3 Channel coding and interleaving

The choice of channel coding depends on the propagation environment and spectrum efficiency and quality requirements of the various services. Applications of large cells, especially in case of satellite component, usually require more powerful channel coding, while microcellular systems, used in a pedestrian environment, may allow less complex channel coding. For the choice of the channel coding with or without interleaving, it may be desirable to have multiple choices; each optimized to the appropriate service environment.

5.1.4 Duplexing technology

The choice of the duplexing technology mainly affects the choices of the RF-channel bandwidth and the frame length. Duplexing technology may be independent of the access technology since for example either FDD (Frequency Division Duplex) or TDD (Time Division Duplex) may be used with either TDMA or CDMA systems.

5.1.5 Physical channel structure and multiplexing

The physical channel is a specified portion of one or more radio frequency channels as defined in frequency, time and code domain.

5.1.6 Frame structure

The frame structure depends mainly on the multiple access technology (e.g. FDMA, TDMA, CDMA) and the duplexing technology (e.g. FDD, TDD). Commonality should be maximised by maintaining the same frame structure whenever possible. That is, data fields identifying physical and logical channels, as well as the frame length should be maintained when possible.

5.1.7 RF channel parameters

RF channel parameters include parameters such as bandwidth, allocation and channel spacing.

5.2 Other functional blocks

5.2.1 Source coder

The choice of the source coder may generally be made independently of the access method.

5.2.2 Interworking

The interworking function (IWF) converts standard data services to the rates used internally by the radio transmission subsystem. The IWF feeds into the channel coder on the transmit side and is fed from the channel decoder on the receiver side.

6 Technical characteristics chosen for evaluation

This section is same as in [2] except that criteria for backwards compatibility and asymmetric services has been added into Section 6.1.4.

As a radio interface is only one part of a system, the choice of a specific SRTT (see Figure 5.1), for the provision of a radio interface for IMT-2000/FPLMTS, requires consideration of the broad technical characteristics so as to cover the most important aspects that may impact the economics and performance of the system.

For practical reasons, a limited set of these technical characteristics has been chosen. It by no means implies that other (technical and non-technical) criteria are not relevant or significant. It is however believed that those essential system aspects which are impacted by the RTTs are fairly covered with the selected technical characteristics.

Given the difficulties of predicting the future, in particular when dealing with technology, sufficient provision is also made for a fair technical evaluation for all possible technologies, particularly new technologies. This is accomplished by making sure that it is not only the technology itself which is evaluated but also its impact on the system performance and economics.

6.1 Criteria for evaluation of radio transmission technologies

Each of the technical characteristics defined hereafter will be used as evaluation criterion and is further defined in the specific technical attributes in Annex C. The RTTs description template is given in Annex A.

Some of the criteria such as coverage or spectrum efficiency are measurable and may be numerically evaluated. Specific test scenarios are given in Annex B so as to enable the proponents and evaluators to calculate and verify the required figures on a common and fair basis.

Other criteria such as flexibility are of a more subjective nature and need to be assessed qualitatively. Advantages and drawbacks of the proposed technologies are to be given and commented on by the proponents and evaluators considering the technical parameters that are judged relevant to the criterion. A list of technical parameters that will be considered for each evaluation criterion, is given in Annex C.

6.1.1 Spectrum efficiency

Optimum use of the radio spectrum is of great importance to UMTS radio interface. In general the more telecommunications traffic that can be handled at a given quality, for a given frequency band, the more efficiently the spectrum is used. Evaluation of voice traffic capacity and information capacity should take into account frequency reuse and signalling overhead, among other parameters, as noted in Annex B.

6.1.2 Technology complexity - effect on cost of installation and operation

This criterion expresses the impact of a given RTT on complexity (and hence on cost) of implementation (equipment, infrastructure, installation, etc.) i.e., the less complex the better. In order to achieve the minimum cost and best reliability of equipment, the technologies selected should have a level of complexity consistent with the state of technology, the desired service objectives and the radio environment. Some technologies have several possible methods of implementation which allow a compromise between complexity/cost and performance.

The installed and ongoing cost of UMTS is influenced by both the transmission technology and the level of quality and reliability. At a given quality level, it is impacted by the complexity of the radio hardware, the other necessary network infrastructures, and the ongoing operational aspects of UMTS.

6.1.3 Quality

Most of the quality parameters which are dealt with in other Recommendations are minimum requirements which must be met and are not to be treated in the evaluation process. RTTs will be evaluated on the impact of transmission processing delay on the end-to-end delay, expected average bit error ratio (BER) under the stated test conditions, on their maximum supportable bit rate under specified conditions and their overall ability to minimise circuit disruption during handover. In addition, they will be evaluated on their ability to sustain quality under certain extreme conditions such as system overload, hardware failures, interference, etc.

6.1.4 Flexibility of radio technologies

This criterion is of utmost importance for UMTS operators. UMTS system will have to be flexible in terms of deployment, service provision, resource planning and spectrum sharing. Among the items that need to be considered are:

- ability to balance capacity versus RF signal quality as long as minimum performance requirements are met;
- adaptability of system(s) to different and/or time-varying propagation and traffic environments;
- ease of radio resource management;
- ability to accommodate fixed wireless access (FWA) architecture;
- ease of service provision including variable bit rate capability, asymmetric services, packet data mode transmission and simultaneous transmission of voice and non-voice services;
- ability to provide interoperability and backwards compatibility including implementation of dualmode handportables with GSM/DCS.

- ability to coexist in a co-ordinated manner with existing systems. See subclause 8.3 and 8.4 of UMTS 21.01.

and for terrestrial considerations:

- ability to accommodate mixed-cell (pico, micro, macro, and mega) architecture;
- suitability for multiple operators in the same/overlapping service areas. RTTs will be compared based on their ability to:
 - i) efficiently share a common spectrum allocation;
 - ii) share network infrastructures (for example in areas of low subscriber density);
 - iii) provide for handover between systems run by different operators.

6.1.5 Implication on network interface

It is desirable to minimise the impact of the radio subsystems on fixed network interfaces. The choice of RTTs may affect both the actual network interfaces required in UMTS for multi-environment operation and the information passed over them. The need for synchronization between base stations (BSs) and between systems sharing common location and spectrum may be different. The requirements placed on the networks by the handover procedure may be different. Cross-environment operation, e.g. PSTN to wireless PBX call transfer, may require additional PSTN functionality. In particular, the number of signalling messages, the actual switching requirements, and the transmission capacity from BSs to switches may be different. RTTs should be evaluated based on the implications they impose on fixed network interfaces.

6.1.6 Handportable performance optimization capability

Handportable UMTS terminals will be used in a broad range of service and radio environments. . As with previous generation wireless systems, the capability for handportable voice and personal data applications will impact the market acceptance and success of UMTS.

The following should be considered when evaluating the RTTs for either individual or multiple operating UMTS environments:

- transmit power requirements;
- transmitter and receiver linearity requirements;
- size and weight as a function of application;
- intermittent reception capability;
- circuit clock rate;
- overall complexity.

6.1.7 Coverage/Power efficiency

In terrestrial systems, the minimum number of BSs per square kilometre for a given frequency assignment to offer a certain amount of traffic with the required coverage is an important figure, at low traffic levels. At low loading, the system will be noise limited and the number of base stations constrained by the maximum range achievable by the technology.

At low loading, range and coverage efficiency are the major considerations, while at high loading, capacity and spectrum efficiency are more important.

Technologies providing the desired level of coverage with fewer base sites for a specific test environment are defined as having higher coverage efficiency.

The coverage efficiency as defined above is not applicable to satellite systems for this evaluation criterion.

In satellite systems the DC power available for conversion into usable RF power is limited and fixed for any given satellite. It is important that this power is used efficiently and yields the maximum number of traffic channels of a given quality. The power efficiency as defined here is not applicable to terrestrial systems.

7 Selected test environments for evaluation

This section is same as in [2].

The test environments for evaluation are discussed in Annex B. The selected test operating environments are the following:

Indoor Office

Outdoor to indoor and pedestrian

Vehicular

Mixed-cell pedestrian/vehicular

8 Evaluation methodology

This section is same as in [2] except that section 9.1.4 has been removed.

After the candidate SRTT has been compared against the technical requirements and objectives and a preliminary verification of the technology has been made (Steps 2 and 3 in Section 8), a technical evaluation of the candidate SRTT is made against each evaluation criterion given in Section 6.1. This evaluation will be made in the appropriate test environments using the deployment models described in Annex B. Candidate SRTTs will be evaluated based on technical descriptions that are submitted using the Technologies Description Template contained in Annex A. The detailed evaluation procedures are given in Annex C, which lists technical attributes that should be considered for the evaluation of SRTTs against each of the evaluation criteria.

The evaluation criteria can be sub-divided into objective and subjective criteria. Objective criteria contain technical attributes that can be assessed on a quantitative basis; subjective criteria contain a mixture of technical attributes that can be assessed on a quantitative basis and technical attributes that can be assessed on a qualitative basis.

Objective criteria	Subjective criteria
1. Spectrum efficiency 7. Coverage efficiency	2. Technology complexity - Effect on cost of installation and operation 3. Quality 4. Flexibility of radio technologies 5. Implication on network interfaces 6. Handportable performance optimization capability

8.1 Objective criteria

For these criteria, the evaluation is made based on the quantitative information submitted for each technical attribute. The independent evaluation groups may comment on the results and request further information or new calculations to further validate the given figures (e.g. by requesting simulation results when only theoretical analyses have been performed). The proponent is allowed to reply to these comments within a given deadline. Final conclusions or comments are then issued by the evaluators, and a summary evaluation for the criteria, as described in Section 9.4, is then given taking into account all the results.

8.2 Subjective criteria

For these criteria, a numerical evaluation is difficult as the information submitted for a technical attribute may be qualitative instead of quantitative. However, a technical-based evaluation is still feasible and beneficial if a summary criteria evaluation approach is taken so as to understand the relative merits and drawbacks of each candidate SRTT. In doing so, the most important technical information for decision-makers is then given as a result of this technical evaluation process. As with objective criteria, the evaluators may comment on the results and request additional information to further validate the SRTT submission. The proponent is allowed to reply to these comments within a given deadline. Final conclusions or comments are then issued by the evaluators, and a summary evaluation for the criteria, as described in Section 9.4, is then given taking into account all the results.

8.3 Evaluation spreadsheet

The following spreadsheet should be used as a guideline for the submission of the evaluation information to the SMG2. It includes an example for information.

Spreadsheet for SRTT A criterion 1

Criterion <i>e.g. Flexibility</i>	Proponent comments	Evaluator comments
1st technical attribute <i>e.g. variable user bit rate capabilities</i>	<i>e.g. how well the SRTT performs with respect to this attribute; how relevant this technical attribute is for the proposed SRTT</i>	<i>e.g. request for clarification, disagreement, etc.; indication of relative importance of this attribute to others within this criterion</i>
2nd technical attribute	This is not relevant as our technology does not use that particular feature, ...	
3rd technical attribute <i>e.g. maximum tolerable Doppler shift</i>	Required figures xxx <i>Comments (e.g. it has been obtained using the following assumptions)</i>	<i>e.g., comments on the validity of the results; request for further hardware verification</i>
...		
Comment sections	General comments from the proponents <i>(e.g. new relevant technical parameters to take into account, etc.)</i>	General comments from the evaluators <i>(e.g. request for clarification, missing points, etc.)</i>
2nd step comments	Reply to the evaluator's comments	Summary criterion evaluation , including information about how the summary evaluation was achieved and the relative importance placed on the technical attributes and other considerations

8.4 Summary evaluations

In order to compare multiple SRTTs, it is useful to have summary evaluations for each SRTT within each evaluation criterion. A summary criterion evaluation may be difficult to make when both qualitative and quantitative attributes must be considered, and when each technical attribute may have different relative importance with the overall evaluation criteria.

To facilitate such summary criterion evaluations, Annex C identifies the importance or relative ranking of the various technical attributes within each of the evaluation criteria. These rankings are based upon current anticipated market needs within some countries. It is recognized that market needs may differ in various countries and may change over time. It is also recognized the some new technical attributes or important considerations may be identified during the evaluation procedure that should impact on any summary criterion evaluation. As such, Annex C provides that evaluation groups may, if appropriate, modify the groupings of technical attributes, or add new attributes or considerations, in determining a summary criterion evaluation.

All evaluation groups are requested to include in the evaluation reports, information on the summary criterion evaluations including the relative importance which was placed on each technical attribute and any other consideration that affected the summary criterion evaluations.

Annex A: Technologies description template

This annex is the same as in REVAL [2] with the following exceptions :

- question related to backwards compatibility into GSM/DCS has been added (A1.2.33)
- elaboration of adaptive antenna capabilities (A1.2.25)
- in items A1.3.1.5.1 and A1.3.1.5.2 there are no more references to the 'penetration values of Annex B' since these values were removed from ETR 04.02
- items A1.2.26, A1.4.3, and A1.4.15 have been amended to address some peculiarities of private systems
- parameters have been divided into two categories: technology independent (ti) and technology dependent (td).

A parameter is to be considered technology independent if it is relevant for all proposals (i.e. it has to be specified for all proposals): e.g. capability to support power control schemes; a parameter is technology dependent if it might be relevant only for some proposals (e.g. TDMA system characteristics which are not relevant for CDMA technologies, or power control characteristics which are relevant only for proposals supporting power control schemes).

- parameters which are not relevant for the selection of UTRA are marked with an asterisk *. They do not need to be defined for SMG2 submission, but are kept for consistency with REVAL template.

Description of the Radio Transmission Technology

The RTT has to be described in a detailed form to get an overview and an understanding of the functionalities of the technical approach. This annex provides a template to aid in the technical description of the characteristics of a candidate SRTT.

The following technical parameters, the relevant templates given in Annex B and any additionally useful information, should be provided for each test environment for which the candidate SRTT is proposed to operate. This can be done by preparing:

- 1) a separate template submission for each test environment; or
- 2) a single submission that includes multiple answers for those technical parameters impacted by a test environment.

In addition to the detailed technical description described below, proponents should assure that their submission meets the overall UMTS objectives as defined in existing Recommendations (see section 4). Submitters should also state if the current ITU policy for IPR is met for their RTT proposals.

The following table describes the technical parameters needed to characterise a proposal. Proponents should feel free to add any new information if required for a better assessment of their proposal.

UMTS may serve both mobile users as well as fixed wireless users sharing common geographical locations and frequency bands. As a result, certain parameters may be designed for one or the other type of user in combination. To account for fixed wireless use of a candidate SRTT, the description given in the template should indicate when a parameter has been designed for dual use.

Table contents

A1.1	Test environment support
A1.2	Technical parameters
A1.3	Expected performances
A1.4	Technology design constraints
A1.5	Information required for terrestrial link budget template
A1.6	Satellite system configuration

	A1.1	Test environment support
ti	A1.1.1	In what test environments will the SRTT operate?
td	A1.1.2	If the SRTT supports more than one test environment, what test environment does this technology description template address?
	A1.1.3	Does the SRTT include any feature in support of FWA application ? Provide detail about impact of those features on the technical parameters provided in this template, stating whether the technical parameters provided apply for mobile as well as for FWA applications.
	A1.2	Technical parameters Note : Parameters for both forward link and reverse link should be described separately, if necessary.
ti	A1.2.1	What is the minimum frequency band required to deploy the system (MHz)?
ti	A1.2.2	What is the duplex method: TDD or FDD
ti	A1.2.2.1	What is the minimum up/down frequency separation for FDD?
ti	A1.2.2.2	What is requirement of transmit/receive isolation? Does the proposal require a duplexer in either the mobile or base station.
ti	A1.2.3	Does the SRTT allow asymmetric transmission to use the available spectrum? Characterize.
ti	A1.2.4	What is the RF channel spacing (kHz)? In addition, does the SRTT use interleaved frequency allocation? Note: Interleaved frequency allocation; allocating the 2nd adjacent channel instead of adjacent channel at neighboring cluster cell is so called "interleaved frequency allocation". If a proponent is going to employ this allocation type, proponent should be stated at A1.2.4 and fill A1.2.15 of protection ratio for both of adjacent and 2nd adjacent channel.
ti	A1.2.5	What is the bandwidth per duplex RF channel (MHz) measured at the 3 dB down points? It is given by (bandwidth per RF channel) x (1 for TDD and 2 for FDD). Please provide detail.
ti	A1.2.5.1	Does the proposal offer multiple or variable RF channel bandwidth capability? If so, are multiple bandwidths or variable bandwidths provided for the purposes of compensating the transmission medium for impairments but intended to be feature transparent to the end user?

ti	A1.2.6	<p>What is the RF channel bit rate (kbps)? .</p> <p>The maximum modulation rate of RF (after channel encoding, adding of in-band control signaling and any overhead signaling) possible to transmit carrier over an RF channel, i.e. independent of access technology and of modulation schemes.</p>
ti	A1.2.7	<p>Frame Structure : Describe the frame structure to give sufficient information such as;</p> <ul style="list-style-type: none"> - frame length - the number of time slots per frame - guard time or the number of guard bits - user information bit rate for each time slot - channel bit rate (after channel coding) - channel symbol rate (after modulation) - associated control channel (ACCH) bit rate - power control bit rate. <p>Note 1: Channel coding may include FEC, CRC, ACCH, power control bits and guard bits. Provide detail.</p> <p>Note 2: Describe the frame structure for forward link and reverse link, respectively.</p> <p>Note 3: Describe the frame structure for each user information rate.</p>
ti	A1.2.8	Does the SRTT use frequency hopping? If so characterize and explain particularly the impact (e.g. improvements) on system performance.
td	A1.2.8.1	What is the hopping rate?
td	A1.2.8.2	What is the number of the hopping frequency sets?
ti	A1.2.8.3	Are base stations synchronized or non-synchronized?
ti	A1.2.9	Does the SRTT use spreading scheme?
td	A1.2.9.1	What is the chip rate (Mchip/s): Rate at input to modulator.
td	A1.2.9.2	What is the processing gain: $10 \log (\text{Chip rate} / \text{Information rate})$.
td	A1.2.9.3	Explain the uplink and downlink code structures and provide the details about the types (e.g. PN code, Walsh code) and purposes (e.g. spreading, identification, etc.) of the codes.

ti	A1.2.10	Which access technology does the proposal use: TDMA, FDMA, CDMA , hybrid, or a new technology? In the case of CDMA which type of CDMA is used: Frequency Hopping (FH) or Direct Sequence (DS) or hybrid? Characterize.
ti	A1.2.11	What is the baseband modulation technique? If both the data modulation and spreading modulation are required, please describe detail. What is the peak to average power ratio after baseband filtering (dB)?
ti	A1.2.12	What are the channel coding (error handling) rate and form for both the forward and reverse links? e.g. - Does the SRTT adopt FEC (Forward Error Correction) or other schemes? - Does the SRTT adopt unequal error protection? Please provide details. - Does the SRTT adopt soft decision decoding or hard decision decoding? Please provide details. - Does the SRTT adopt iterative decoding (e.g. turbo codes)? Please provide details. - Other schemes.
ti	A1.2.13	What is the bit interleaving scheme? Provide detailed description for both up link and down link.
ti	A1.2.14	Describe the taken approach for the receivers (MS and BS) to cope with multipath propagation effects (e.g. via equalizer, RAKE receiver, etc.).
ti	A1.2.14.1	Describe the robustness to intersymbol interference and the specific delay spread profiles that are best or worst for the proposal.
ti	A1.2.14.2	Can rapidly changing delay spread profile be accommodated? Please describe.
ti	A1.2.15	What is the Adjacent channel protection ratio? In order to maintain robustness to adjacent channel interference, the SRTT should have some receiver characteristics that can withstand higher power adjacent channel interference. Specify the maximum allowed relative level of adjacent RF channel power in dBc. Please provide detail how this figure is assumed.
	A1.2.16	Power classes
ti	A1.2.16.1	Mobile terminal emitted power: What is the radiated antenna power measured at the antenna? For terrestrial component, please give (in dBm). For satellite component, the mobile terminal emitted power should be given in EIRP (dBm).
ti	A1.2.16.1.1	What is the maximum peak power transmitted while in active or busy state?
ti	A1.2.16.1.2	What is the time average power transmitted while in active or busy state? Provide detailed explanation used to calculate this time average power.
ti	A1.2.16.2	Base station transmit power per RF carrier for terrestrial component

ti	A1.2.16.2.1	What is the maximum peak transmitted power per RF carrier radiated from antenna?
ti	A1.2.16.2.2	What is the average transmitted power per RF carrier radiated from antenna?
ti	A1.2.17	What is the maximum number of voice channels available per RF channel that can be supported at one base station with 1 RF channel (TDD systems) or 1 duplex RF channel pair (FDD systems), while still meeting G.726 performance requirements?
ti	A1.2.18	<p>Variable bit rate capabilities: Describe the ways the proposal is able to handle variable base band transmission rates. For example, does the SRTT use:</p> <ul style="list-style-type: none"> -adaptive source and channel coding as a function of RF signal quality -variable data rate as a function of user application -variable voice/data channel utilization as a function of traffic mix requirements? <p>Characterize how the bit rate modification is performed. In addition, what are the advantages of your system proposal associated with variable bit rate capabilities?</p>
td	A1.2.18.1	What are the user information bit rates in each variable bit rate mode?
ti	A1.2.19 *	What kind of voice coding scheme or CODEC is assumed to be used in proposed SRTT? If the existing specific voice coding scheme or CODEC is to be used, give the name of it. If a special voice coding scheme or CODEC (e.g. those not standardized in standardization bodies such as ITU) is indispensable for the proposed SRTT, provide detail, e.g. scheme, algorithm, coding rates, coding delays and the number of stochastic code books.
ti	A1.2.19.1	Does the proposal offer multiple voice coding rate capability? Please provide detail.
ti	A1.2.20	<p>Data services: Are there particular aspects of the proposed technologies which are applicable for the provision of circuit-switched, packet-switched or other data services like asymmetric data services? For each service class (A, B, C and D) a description of SRTT services should be provided, at least in terms of bit rate, delay and BER/FER.</p> <p>Note 1: See [draft new] Recommendation [FPLMTS.TMLG] for the definition of</p> <ul style="list-style-type: none"> - "circuit transfer mode" - "packet transfer mode" - "connectionless service" <p>and for the aid of understanding "circuit switched" and "packet switched" data services</p> <p>Note 2: See ITU-T Recommendation I.362 for details about the service classes A, B, C and D</p>
ti	A1.2.20.1	For delay constrained, connection oriented. (Class A)
ti	A1.2.20.2	For delay constrained, connection oriented, variable bit rate (Class B)
ti	A1.2.20.3	For delay unconstrained, connection oriented. (Class C)
ti	A1.2.20.4	For delay unconstrained, connectionless. (Class D)

ti	A1.2.21	Simultaneous voice/data services: Is the proposal capable of providing multiple user services simultaneously with appropriate channel capacity assignment?
		Note : The followings describe the different techniques that are inherent or improve to a great extent the technology described above to be presented: Description for both BS and MS are required in attributes from A2..22 through A1.2.23.2.
ti	A1.2.22	Power control characteristics: Is power control scheme included in the proposal? Characterize the impact (e.g. improvements) of supported power control schemes on system performance.
td	A1.2.22.1	What is the power control step size in dB?
td	A1.2.22.2	What are the number of power control cycles per second?
td	A1.2.22.3	What is the power control dynamic range in dB?
td	A1.2.22.4	What is the minimum transmit power level with power control?
td	A1.2.22.5	What is the residual power variation after power control when SRTT is operating? Please provide details about the circumstances (e.g. in terms of system characteristics, environment, deployment, MS-speed, etc.) under which this residual power variation appears and which impact it has on the system performance.
ti	A1.2.23	Diversity combining in mobile station and base station : Are diversity combining schemes incorporated in the design of the SRTT?
td	A1.2.23.1	Describe the diversity techniques applied in the mobile station and at the base station , including micro diversity and macro diversity, characterizing the type of diversity used, for example: - time diversity : repetition, RAKE-receiver, etc., - space diversity : multiple sectors, multiple satellite, etc., - frequency diversity : FH, wideband transmission, etc., - code diversity : multiple PN codes, multiple FH code, etc., - other scheme. Characterize the diversity combining algorithm, for example, switch diversity, maximal ratio combining, equal gain combining. Additionally, provide supporting values for the number of receivers (or demodulators) per cell per mobile user. State the dB of performance improvement introduced by the use of diversity. For the mobile station: what is the minimum number of RF receivers (or demodulators) per mobile unit and what is the minimum number of antennas per mobile unit required for the purpose of diversity reception? These numbers should be consistent to that assumed in the link budget template in Annex B and that assumed in the calculation of the "capacity" defined at A1.3.1.5.

td	A1.2.23.2	What is the degree of improvement expected in dB? Please also indicate the assumed condition such as BER and FER.
ti	A1.2.24	Handover/Automatic Radio Link Transfer (ALT) : Do the radio transmission technologies support handover? Characterize the type of handover strategy (or strategies) which may be supported, e.g. mobile station assisted handover. Give explanations on potential advantages, e.g. possible choice of handover algorithms. Provide evidence whenever possible.
td	A1.2.24.1	What is the break duration (sec) when a handover is executed? In this evaluation, a detailed description of the impact of the handover on the service performance should also be given. Explain how the estimate derived.
td	A1.2.24.2	For the proposed SRTT, can handover cope with rapid decrease in signal strength (e.g. street corner effect)? Give a detailed description of - the way the handover detected, initiated and executed, - how long each of this action lasts (minimum/maximum time in msec), - the timeout periods for these actions.
ti	A1.2.25	Characterize how does the proposed SRTT react to the system deployment in terms of the evolution of coverage and capacity (e.g. necessity to add new cells and/or new carriers): - in terms of frequency planning - in terms of the evolution of adaptive antenna technology using mobile identity codes (e.g. sufficient number of channel sounding codes in a TDMA type of system) - other relevant aspects
ti	A1.2.26	Sharing frequency band capabilities: To what degree is the proposal able to deal with spectrum sharing among UMTS systems as well as with all other systems: - spectrum sharing between operators - spectrum sharing between terrestrial and satellite UMTS systems - spectrum sharing between UMTS and non-UMTS systems - spectrum sharing between private and public UMTS operators - other sharing schemes.

ti	A1.2.27	Dynamic channel allocation: Characterize the DCA schemes which may be supported and characterize their impact on system performance (e.g. in terms of adaptability to varying interference conditions, adaptability to varying traffic conditions, capability to avoid frequency planning, impact on the reuse distance, etc.)
ti	A1.2.28	Mixed cell architecture: How well do the technologies accommodate mixed cell architectures (pico, micro and macrocells)? Does the proposal provide pico, micro and macro cell user service in a single licensed spectrum assignment, with handoff as required between them? (terrestrial component only) Note: Cell definitions are as follows: pico - cell hex radius (r) < 100 m micro - 100 m < (r) < 1000 m macro - (r) > 1000 m
ti	A1.2.29	Describe any battery saver / intermittent reception capability
td	A1.2.29.1	Ability of the mobile station to conserve standby battery power: Please provide details about how the proposal conserve standby battery power.
td	A1.2.30	Signaling transmission scheme: If the proposed system will use radio transmission technologies for signaling transmission different from those for user data transmission, describe details of signaling transmission scheme over the radio interface between terminals and base (satellite) stations.
td	A1.2.30.1	Describe the different signaling transfer schemes which may be supported, e.g. in connection with a call, outside a call. Does the SRTT support new techniques? Characterize. Does the SRTT support signalling enhancements for the delivery of multimedia services? Characterize.
ti	A1.2.31	Does the SRTT support a Bandwidth on Demand (BOD) capability? Bandwidth on Demand refers specifically to the ability of an end-user to request multi-bearer services. Typically this is given as the capacity in the form of bits per second of throughput. Multi bearer services can be implemented by using such technologies as multi carrier, multi time slot or multi codes. If so, characterize these capabilities. Note: BOD does not refer to the self-adaptive feature of the radio channel to cope with changes in the transmission quality (see A1.2.5.1).
ti	A1.2.32	Does the SRTT support channel aggregation capability to achieve higher user bit rates?
	A1.3	Expected Performances
	A1.3.1	for terrestrial test environment only

ti	A1.3.1.1	<p>What is the achievable BER floor level (for voice)?</p> <p>Note: BER floor level under BER measuring condition defined in Annex B using the data rates indicated in section 1 of Annex B.</p>
ti	A1.3.1.2	<p>What is the achievable BER floor level (for data)?</p> <p>Note: BER floor level under BER measuring condition defined in Annex B using the data rates indicated in section 1 of Annex B.</p>
ti	A1.3.1.3	<p>What is the maximum tolerable delay spread (in nsec) to maintain the voice and data service quality requirements?</p> <p>Note: The BER is an error floor level measured with the Doppler shift given in the BER measuring conditions of ANNEX B.</p>
ti	A1.3.1.4	<p>What is the maximum tolerable doppler shift (in Hz) to maintain the voice and data service quality requirements?</p> <p>Note: The BER is an error floor level measured with the delay spread given in the BER measuring conditions of ANNEX B.</p>
ti	A1.3.1.5	<p>Capacity : The capacity of the radio transmission technology has to be evaluated assuming the deployment models described in ANNEX B and technical parameters from A1.2.22 through A1.2.23.2.</p>
ti	A1.3.1.5.1	<p>What is the voice traffic capacity per cell (not per sector): Provide the total traffic that can be supported by a single cell in Erlangs/MHz/cell in a total available assigned non-contiguous bandwidth of 30 MHz (15 MHz forward/15 MHz reverse) for FDD mode or contiguous bandwidth of 30 MHz for TDD mode. Provide capacities considering the model for the test environment in ANNEX B. The procedure to obtain this value in described in ANNEX B. The capacity supported by not a standalone cell but a single cell within contiguous service area should be obtained here.</p>
ti	A1.3.1.5.2	<p>What is the information capacity per cell (not per sector): Provide the total number of user-channel information bits which can be supported by a single cell in Mbps/MHz/cell in a total available assigned non-contiguous bandwidth of 30 MHz (15 MHz forward / 15 MHz reverse) for FDD mode or contiguous bandwidth of 30 MHz for TDD mode. Provide capacities considering the model for the test environment in ANNEX B. The procedure to obtain this value in described in ANNEX B. The capacity supported by not a standalone cell but a single cell within contiguous service area should be obtained here.</p>
ti	A1.3.1.6	<p>Does the SRTT support sectorization? If yes, provide for each sectorization scheme and the total number of user-channel information bits which can be supported by a single site in Mbps/MHz (and the number of sectors) in a total available assigned non-contiguous bandwidth of 30 MHz (15 MHz forward/15 MHz reverse) in FDD mode or contiguous bandwidth of 30 MHz in TDD mode.</p>
ti	A1.3.1.7	<p>Coverage efficiency : The coverage efficiency of the radio transmission technology has to be evaluated assuming the deployment models described in ANNEX B.</p>

ti	A1.3.1.7.1	What is the base site coverage efficiency in Km^2/site for the lowest traffic loading in the voice only deployment model? Lowest traffic loading means the lowest penetration case described in ANNEX B.
ti	A1.3.1.7.2	What is the base site coverage efficiency in Km^2/site for the lowest traffic loading in the data only deployment model? Lowest traffic loading means the lowest penetration case described in ANNEX B.
	A1.3.2 *	for satellite test environment only
ti	A1.3.2.1 *	What is the required C/No to achieve objective performance defined in ANNEX B?
ti	A1.3.2.2 *	What are the Doppler compensation method and residual Doppler shift after compensation?
ti	A1.3.2.3 *	Capacity : The spectrum efficiency of the radio transmission technology has to be evaluated assuming the deployment models described in ANNEX B.
ti	A1.3.2.3.1 *	What is the voice information capacity per required RF bandwidth (bits/sec/Hz)?
ti	A1.3.2.3.2 *	What is the voice plus data information capacity per required RF bandwidth (bits/sec/Hz)?
ti	A1.3.2.4 *	Normalized power efficiency : The power efficiency of the radio transmission technology has to be evaluated assuming the deployment models described in ANNEX B.
ti	A1.3.2.4.1 *	What is the supported information bit rate per required carrier power-to-noise density ratio for the given channel performance under the given interference conditions for voice?
ti	A1.3.2.4.2 *	What is the supported information bit rate per required carrier power-to-noise density ratio for the given channel performance under the given interference conditions for voice plus data?
ti	A1.3.3	Maximum user bit rate (for data): Specify the maximum user bit rate (kbps) available in the deployment models described in ANNEX B.
ti	A1.3.4	What is the maximum range in meters between a user terminal and a base station (prior to hand-off, relay, etc.) under nominal traffic loading and link impairments as defined in Annex B?

ti	A1.3.5	Describe the capability for the use of repeaters
ti	A1.3.6	<p>Antenna Systems : Fully describe the antenna systems that can be used and/or have to be used; characterize their impacts on systems performance, (terrestrial only) e.g.:</p> <ul style="list-style-type: none"> - Does the SRTT have the capability for the use of remote antennas: Describe whether and how remote antenna systems can be used to extend coverage to low traffic density areas. - Does the SRTT have the capability for the use of distributed antennas: Describe whether and how distributed antenna designs are used, and in which UMTS test environments. - Does the SRTT have the capability for the use of smart antennas (e.g. switched beam, adaptive, etc.): Describe how smart antennas can be used and what is their impact on system performance. - Other antenna systems.
	A1.3.7	Delay (for voice)
ti	A1.3.7.1	What is the radio transmission processing delay due to the overall process of channel coding, bit interleaving, framing, etc., not including source coding? This is given as transmitter delay from the input of the channel coder to the antenna plus the receiver delay from the antenna to the output of the channel decoder. Provide this information for each service being provided. In addition, a detailed description of how this parameter was calculated is required for both the up-link and the down-link.
ti	A1.3.7.2	What is the total estimated round trip delay in msec to include both the processing delay, propagation delay (terrestrial only) and vocoder delay? Give the estimated delay associated with each of the key attributes described in Figure 1 of Annex C that make up the total delay provided.
ti	A1.3.7.3 *	Does the proposed SRTT need echo control?
ti	A1.3.8 *	<p>What is the MOS level for the proposed codec for the relevant test environments given in Annex B? Specify its absolute MOS value and its relative value with respect to the MOS value of G.711(64k PCM) and G.726 (32k ADPCM).</p> <p>Note: If a special voice coding algorithm is indispensable for the proposed SRTT, the proponent should declare detail with its performance of the codec such as MOS level. (See A1.2.19)</p>
ti	A1.3.9	Description on the ability to sustain quality under certain extreme conditions.
ti	A1.3.9.1	System overload (terrestrial only) : Characterize system behavior and performance in such conditions for each test services in Annex B, including potential impact on adjacent cells. Describe the effect on system performance in terms of blocking grade of service for the cases that the load on a particular cell is 125%, 150%, 175%, and 200% of full load. Also describe the effect of blocking on the immediate adjacent cells. Voice service is to be considered here. Full load means a traffic loading which results in 1% call blocking with the BER of 10^{-3} maintained.

ti	A1.3.9.2	Hardware failures : Characterize system behavior and performance in such conditions. Provide detailed explanation on any calculation.
ti	A1.3.9.3	Interference immunity : Characterize system immunity or protection mechanisms against interference. What is the interference detection method? What is the interference avoidance method?
ti	A1.3.10	Characterize the adaptability of the proposed SRTT to different and/or time varying conditions (e.g. propagation, traffic, etc.) that are not considered in the above attributes of the section A1.3.
	A1.4	Technology Design Constraints
ti	A1.4.1	Frequency stability : Provide transmission frequency stability (not oscillator stability) requirements of the carrier (include long term - 1 year - frequency stability requirements in ppm).
ti	A1.4.1.1	For Base station transmission (terrestrial component only)
ti	A1.4.1.2	For Mobile station transmission
ti	A1.4.2	Out of band and spurious emissions: Specify the expected levels of base or satellite and mobile transmitter emissions outside the operating channel, as a function of frequency offset.
ti	A1.4.3	<p>Synchronisation requirements: Describe SRTT's timing requirements , e.g.</p> <ul style="list-style-type: none"> - Is base station-to-base station or satellite LES-to-LES synchronisation required? Provide precise information, the type of synchronisation, i.e., synchronisation of carrier frequency, bit clock, spreading code or frame, and their accuracy. - Is base station-to-network synchronisation required? (terrestrial only) - State short-term frequency and timing accuracy of base station (or LES) transmit signal. - State source of external system reference and the accuracy required, if used at base station (or LES)(for example: derived from wireline network, or GPS receiver). - State free run accuracy of mobile station frequency and timing reference clock. - State base-to-base bit time alignment requirement over a 24 hour period, in microseconds. - For private systems: can multiple unsynchronized systems coexist in the same environment?
ti	A1.4.4	<p>Timing jitter : For base (or LES) and mobile station give:</p> <ul style="list-style-type: none"> - the maximum jitter on the transmit signal, - the maximum jitter tolerated on the received signal. <p>Timing jitter is defined as RMS value of the time variance normalized by symbol duration.</p>

ti	A1.4.5	Frequency synthesizer : What is the required step size, switched speed and frequency range of the frequency synthesizer of mobile stations?
ti	A1.4.6*	Does the proposed system require capabilities of fixed networks not generally available today?
td	A1.4.6.1	Describe the special requirements on the fixed networks for the handover procedure. Provide handover procedure to be employed in proposed SRTT in detail.
ti	A1.4.7	Fixed network Feature Transparency
ti	A1.4.7.1*	Which service(s) of the standard set of ISDN bearer services can the proposed SRTT pass to users without fixed network modification.
ti	A1.4.8	Characterize any radio resource control capabilities that exist for the provision of roaming between a private (e.g., closed user group) and a public UMTS operating environment.
ti	A1.4.9	Describe the estimated fixed signaling overhead (e.g., broadcast control channel, power control messaging). Express this information as a percentage of the spectrum which is used for fixed signaling. Provide detailed explanation on your calculations.
ti	A1.4.10	Characterize the linear and broadband transmitter requirements for base and mobile station. (terrestrial only)
ti	A1.4.11	Are linear receivers required? Characterize the linearity requirements for the receivers for base and mobile station. (terrestrial only)
ti	A1.4.12	Specify the required dynamic range of receiver. (terrestrial only)
ti	A1.4.13	<p>What are the signal processing estimates for both the handportable and the base station?</p> <ul style="list-style-type: none"> - MOPS (Mega Operation Per Second) value of parts processed by DSP - gate counts excluding DSP - ROM size requirements for DSP and gate counts in kByte - RAM size requirements for DSP and gate counts in kByte <p>Note 1: At a minimum the evaluation should review the signal processing estimates (MOPS, memory requirements, gate counts) required for demodulation, equalization, channel coding, error correction, diversity processing (including RAKE receivers), adaptive antenna array processing, modulation, A-D and D-A converters and multiplexing as well as some IF and baseband filtering. For new technologies, there may be additional or alternative requirements (such as FFTs etc.).</p> <p>Note 2 : The signal processing estimates should be declared with the estimated condition such as assumed services, user bit rate and etc.</p>

ti	A1.4.14*	Dropped calls: Describe how the SRTT handles dropped calls. Does the proposed SRTT utilize a transparent reconnect procedure - that is, the same as that employed for handoff?
ti	A1.4.15	<p>Characterize the frequency planning requirements:</p> <ul style="list-style-type: none"> - Frequency reuse pattern: given the required C/I and the proposed technologies, specify the frequency cell reuse pattern (e.g. 3-cell, 7-cell, etc.) and, for terrestrial systems, the sectorization schemes assumed; - Characterize the frequency management between different cell layers; - Does the SRTT use interleaved frequency allocation? - Are there any frequency channels with particular planning requirements? - Can the SRTT support self planning techniques? - All other relevant requirements <p>Note: Interleaved frequency allocation is to allocate the 2nd adjacent channel instead of adjacent channel at neighboring cluster cell.</p>
ti	A1.4.16	Describe the capability of the proposed SRTT to facilitate the evolution of existing radio transmission technologies used in mobile telecommunication systems migrate toward this SRTT. Provide detail any impact and constraint on evolution.
ti	A1.4.16.1	Does the SRTT support backwards compatibility into GSM/DCS in terms of easy dual mode terminal implementation, spectrum co-existence and handover between UMTS and GSM/DCS?
ti	A1.4.17	Are there any special requirements for base site implementation? Are there any features which simplify implementation of base sites? (terrestrial only)
ti	A1.5	Information required for terrestrial link budget template: Proponents should fulfill the link budget template given in Table 1.3 of Annex B and answer the following questions.
ti	A1.5.1	What is the base station noise figure (dB)?
ti	A1.5.2	What is the mobile station noise figure (dB)?
ti	A1.5.3	What is the base station antenna gain (dBi)?
ti	A1.5.4	What is the mobile station antenna gain (dBi)?
ti	A1.5.5	What is the cable, connector and combiner losses (dB)?
ti	A1.5.5	What are the number of traffic channels per RF carrier?
ti	A1.5.6	What is the SRTT operating point (BER/FER) for the required E_b/N_0 in the link budget template?
ti	A1.5.7	What is the ratio of intra-sector interference to sum of intra-sector interference and inter-sector interference within a cell (dB)?

ti	A1.5.8	What is the ratio of in-cell interference to total interference (dB)?
ti	A1.5.9	What is the occupied bandwidth (99%) (Hz)?
ti	A1.5.10	What is the information rate (dBHz)?
	A1.6 *	Satellite System Configuration (applicable to satellite component only) : Configuration details in this sub-section are not to be considered as variables. They are for information only.
	A1.6.1 *	Configuration of satellite constellation
	A1.6.1.1 *	GSO, HEO, MEO, LEO or combination?
	A1.6.1.2 *	What is the range of height where satellites are in active communication?
	A1.6.1.3 *	What is the orbit inclination angle?
	A1.6.1.4 *	What are the number of orbit planes?
	A1.6.1.5 *	What are the number of satellites per orbit plane?
	A1.6.2 *	What is the configuration of spot beams/cell layout pattern?
	A1.6.3 *	What is the frequency reuse plan among spot beams?
	A1.6.4 *	What is the service link G/T of satellite beam (average, minimum)?
	A1.6.5 *	What is the service link saturation EIRP of each beam (average, minimum), when configured to support 'Hot spot'?
	A1.6.6 *	What is the service link total saturation EIRP per satellite?
	A1.6.7 *	Satellite e.i.r.p. (effective isotropic radiated power) per RF carrier for satellite component
	A1.6.7.1 *	What is the maximum peak e.i.r.p. transmitted per RF carrier?
	A1.6.7.2 *	What is the average e.i.r.p. transmitted per RF carrier?
	A1.6.8 *	What is the feeder link information?
	A1.6.9 *	What is the slot timing adjustment method (mainly applicable to TDMA system)?
	A1.6.10 *	What is the satellite diversity method, if applicable?

Annex B: Test environments and deployment models

This annex describes the reference scenarios (test environments and deployment models) and propagation models necessary to elaborate the performance figures of candidate SRTTs for the UMTS Terrestrial Radio Access system UTRA. These reference scenarios are based on REVAL ones [2] in order to ease the submission of UTRA as a candidate for IMT-2000/FPLMTS.

Editor's notes : Changes with respect to REVAL Annex 2 Part 1 - Terrestrial Component

This section is same as in REVAL with the following exceptions:

- in Table 1.0 number of bit rates have been reduced , delay values have been added from 04-01 and voice activity factor has been set to 50%.
- the REVAL model for packet data in Table 1.0 has been replaced by a new model described in Table 1.1 and Figure 1.0.
- deployment Model in section 1.3.2 are different from REVAL. New packet data and mixed service models are used.

B.1 Test Environments

This section will provide the reference model for each test operating environment. These test environments are intended to cover the range of UMTS operating environments. The necessary parameters to identify the reference models include the test propagation environments, traffic conditions, user information rate for prototype voice and data services, and the objective performance criteria for each test operating environment.

The test operating environments are considered as a basic factor in the evaluation process of the RTTs. The reference models are used to estimate the critical aspects, such as the spectrum, coverage and power efficiencies. This estimation will be based on system-level calculations and link-level software simulations using propagation and traffic models.

B.1.1 Mapping of high level requirements onto Test environments

This section presents a mapping of high level services requirements onto Test environments described in the reminder of this document. The mapping consists in identifying the maximal user bit rate in each Test environment, together with the maximal speed, expected range and associated wideband channel model for evaluation purposes. This should be considered in the design and evaluation of each proposal.

High level description	Maximal bit rate	Maximal speed	Test environment Channel models	Cell coverage
Rural outdoor	144 kbit/s	500 km/h	Vehicular Channel A & B	Macrocell
Suburban outdoor	384 kbit/s	120 km/h	Outdoor to Indoor and Pedestrian Channel A & B	Microcell
			Vehicular Channel A	Macrocell
Indoor/ Low range outdoor	2048 kbit/s	10 km/h	Indoor Channel A & B	Picocell
			Outdoor to Indoor and Pedestrian Channel A	Microcell

B.1.2 Services description

B.1.2.1 Test services characteristics

Critical aspects of SRTTs, such as spectrum and coverage efficiencies, cannot be fairly estimated independently of appropriate UMTS services. These UMTS services are, as minimum, characterised by:

- ranges of supported data rates,
- BER requirements,
- one way delay requirements,
- activity factor,
- traffic models.

Table 1.0 provides a list of test data rates for evaluation purposes.

Table 1.0: List of test data rates for evaluation purposes

Test environments	Indoor Office	Outdoor to Indoor and Pedestrian	Vehicular 120 km/h	Vehicular 500 km/h
Test services	bit rates (values) BER Channel activity	bit rates (values) BER Channel activity	bit rates (values) BER Channel activity	bit rates (values) BER Channel activity
Representative low delay data bearer for speech* ¹	8 kbps $\leq 10^{-3}$ 20 ms 50%	8 kbps $\leq 10^{-3}$ 20 ms 50%	8 kbps $\leq 10^{-3}$ 20 ms 50%	8 kbps $\leq 10^{-3}$ 20 ms 50%
LDD Data (circuit-switched, low delay)* ¹	144-384-2048 kbps $\leq 10^{-6}$ 50 ms 100%	64 - 144 - 384 kbps $\leq 10^{-6}$ 50 ms 100%	32 - 144 - 384 kbps $\leq 10^{-6}$ 50 ms 100%	32 -- 144 kbps $\leq 10^{-6}$ 50 ms 100%
LCD Data (circuit-switched, long delay constrained)* ¹	144-384-2048 kbps $\leq 10^{-6}$ 300 ms 100%	64 - 144 - 384 kbps $\leq 10^{-6}$ 300 ms 100%	32 - 144 - 384 kbps $\leq 10^{-6}$ 300 ms 100%	32 - - 144 kbps $\leq 10^{-6}$ 300 ms 100%
UDD Data (packet) Connection-less information types	See section 1.2.2	See section 1.2.2	See section 1.2.2	See section 1.2.2

*¹ Proponents must indicate the achieved one-way delay (excluding propagation delay, delay due to speech framing and processing delay of voice channel coding) for all the test services.

NOTE: For LDD services, a BER threshold of 10^{-4} will be considered for the initial comparison phase of the different concepts in order to reduce simulation times. The BER threshold of 10^{-6} will be considered in the optimisation phase.

NOTE: For TDD services refer to Annex D

B.1.2.2 Traffic models

Real time services

For all real time test services, calls should be generated according to a Poisson process assuming a mean call duration of 120 seconds for speech and circuit switched data services.

For speech, the traffic model should be an on-off model, with activity and silent periods being generated by an exponential distribution. Mean value for active and silence periods are equal to 3 seconds and independent on the up and downlink and both are exponentially distributed.

For circuit switched data services, the traffic model should be a constant bit rate model, with 100 % of activity.

Non-real time services

Figure 1.0 depicts a typical WWW browsing **session**, which consists of a sequence of **packet calls**. We only consider the packets from a source which may be at either end of the link but not simultaneously. The user initiates a packet call when requesting an information entity. During a packet call several **packets** may be generated, which means that the packet call constitutes of a bursty sequence of packets, see [ref 1] and [ref 2]. It is very important to take this phenomenon into account in the traffic model. The burstyness during the packet call is a characteristic feature of packet transmission in the fixed network.

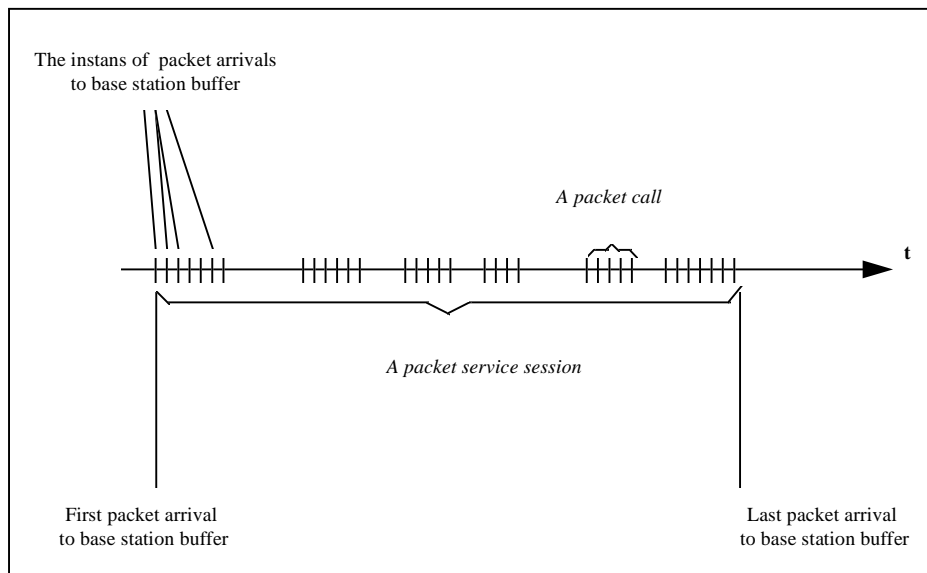

Figure 1.0. Typical characteristic of a packet service session.

A packet service session contains one or several packet calls depending on the application. For example in a WWW browsing session a packet call corresponds the downloading of a WWW document. After the document is entirely arrived to the terminal, the user is consuming certain amount of time for studying the information. This time interval is called **reading time**. It is also possible that the session contains only one packet call. In fact this is the case for a file transfer (FTP). Hence, the following must be modelled in order to catch the typical behaviour described in Figure 1.:

- Session arrival process
- Number of packet calls per session, N_{pc}
- Reading time between packet calls, D_{pc}
- Number of datagrams within a packet call, N_d
- Inter arrival time between datagrams (within a packet call) D_d
- Size of a datagram, S_d

Note that the session length is modelled implicitly by the number of events during the session.

Next it will be described how these six different events are modelled. The geometrical distribution is used (discrete representation of the exponential distribution), since the simulations are using discrete time scale.

Session arrival process: How do session arrive to the system. The arrival of session set-ups to the network is modelled as a Poisson process. For each service there is a separate process. It is important to note that this process for each service only generates the time instants when service calls begin and it has *nothing to do with call termination*.

The number of packet call requests per session, N_{pc} : This is a geometrically distributed random variable with a mean $\mu_{N_{pc}}$ [packet calls], i.e.,

$$N_{pc} \in Geom(\mu_{N_{pc}}).$$

The reading time between two consecutive packet call requests in a session, D_{pc} : This is a geometrically distributed random variable with a mean $\mu_{D_{pc}}$ [model time steps], i.e.,

$$D_{pc} \in Geom(\mu_{D_{pc}}).$$

Note that the reading time starts when the last packet of the packet call is completely received by the user. The reading time ends when the user makes a request for the next packet call.

The number of packets in a packet call, N_d : *The traffic model should be able to catch the various characteristic features possible in the future UMTS traffic. For this reason different statistical distributions can be used to generate the number of packets.* For example N_d can be geometrically distributed random variable with a mean μ_{N_d} [packet], i.e.,

$$N_d \in Geom(\mu_{N_d}).$$

It must be possible to select the statistical distributions that describes best the traffic case under study should be selected. An extreme case would be that the packet call contains a single large packet.

The time interval between two consecutive packets inside a packet call, D_d : This is a geometrically distributed random variable with a mean μ_{D_d} [model time steps], i.e.,

$$D_d \in Geom(\mu_{D_d}).$$

Naturally, if there are only one packet in a packet call, this is not needed.

Packet size, S_d : The traffic model can use such packet size distribution that suits best for the traffic case under study. Pareto distribution with cut-off is used.

The normal Pareto distribution (without cut-off) is defined by:

$$\left\{ \begin{array}{l} f_x(x) = \frac{\alpha \cdot k^\alpha}{x^{\alpha+1}}, x \geq k \\ F_x(x) = 1 - \left(\frac{k}{x}\right)^\alpha, x \geq k \\ \mu = \frac{k\alpha}{\alpha-1}, \alpha > 1 \\ \sigma^2 = \frac{k^2 \cdot \alpha}{(\alpha-2) \cdot (\alpha-1)^2}, \alpha > 2 \end{array} \right.$$

PacketSize is defined with the following formula:

$$\text{PacketSize} = \min(P, m),$$

where P is normal Pareto distributed random variable ($\alpha=1.1$, $k=81.5$ bytes) and m is maximum allowed packet size, $m=66666$ bytes. The PDF of the PacketSize becomes:

$$f_n(x) = \begin{cases} \alpha \cdot k^\alpha \\ x^{\alpha+1}, k \leq x < m \\ \beta, x = m \end{cases}$$

where β is the probability that $x > m$. It can easily be calculated as:

$$\beta = \int_m^\infty f_x(x) dx = \left(\frac{k}{m}\right)^\alpha, \alpha > 1$$

Then it can be calculated as:

$$\mu_n = \int_{-\infty}^\infty x f_n(x) dx = \int_k^{m-} \frac{\alpha k^\alpha}{x^{\alpha+1}} dx + m \left(\frac{k}{m}\right)^\alpha = \dots \text{calculating} \dots = \frac{\alpha k - m \left(\frac{k}{m}\right)^\alpha}{\alpha - 1}$$

with the parameters above the average size is:

$$\mu_n = 480 \text{ bytes}$$

Table 1.1 gives default mean values for the distributions of typical www service. According to the values for α and k in the Pareto distribution, the average packet size μ is 480 bytes. Average requested filesize is $\mu_{Nd} \times \mu = 25 \times 480$ bytes \approx 12 kBytes. The interarrival time is adjusted in order to get different average bit rates at the source level.

Table 1.1: Characteristics of connection-less information types

Packet based information types	Average number of packet calls within a session	Average reading time between packet calls [s]	Average amount of packets within a packet call []	Average interarrival time between packets [s] ¹	Parameters for packet size distribution
WWW surfing UDD 8 kbit/s	5	412	25	0.5	k = 81.5 (= 1.1
WWW surfing UDD 32 kbit/s	5	412	25	0.125	k = 81.5 (= 1.1
WWW surfing UDD 64 kbit/s	5	412	25	0.0625	k = 81.5 (= 1.1
WWW surfing UDD 144 kbit/s	5	412	25	0.0277	k = 81.5 (= 1.1
WWW surfing UDD 384 kbit/s	5	412	25	0.0104	k = 81.5 (= 1.1
WWW surfing UDD 2048 kbit/s	5	412	25	0.00195	k = 81.5 $\alpha = 1.1$

[ref 1] Anderlind Erik and Jens Zander " A Traffic Model for Non-Real-Time Data Users in a Wireless Radio Network" IEEE Communications letters. Vol 1 No. 2 March 1997.

[ref 2] Miltiades E et al. "A multiuser descriptive traffic source model" IEEE Transactions on communications, vol 44 no 10, October 1996.

¹ The different interarrival times correspond to average bit rates of 8, 32, 64, 144, 384 and 2048 kbit/s.

B.1.2.3 Tests configurations

This section presents the different tests configurations to be considered in the evaluation of the UTRA. This represents an exhaustive list of cases to be considered in the optimisation of the UTRA concept.

For each Test environment the different test service mixtures and coverages types to be considered are listed in Table 1.2. The table also specifies what are the expected results for coverage efficiency and spectrum efficiency in each case.

Table 1.2 - List of Tests configurations

Test environment	Service mixture	Propagation model	Cell coverage	Link level Coverage efficiency	System level Spectrum efficiency
Vehicular 500 km/h	Speech LDD 144 kbit/s LCD 144 kbit/s	Vehicular A & B	Macrocell	X	
Vehicular 250 km/h	Speech LDD 144 kbit/s LCD 144 kbit/s	Vehicular A & B	Macrocell	X	
Vehicular 120 km/h	Speech LDD 32, 144, 384 kbit/s LCD 32, 144, 384 kbit/s UDD 8, 32, 144, 384 50 % speech + 50 % UDD 8 50 % speech + 50 % UDD 384	Vehicular A & B	Macrocell	X	X
Outdoor to Indoor and Pedestrian 3 km/h	Speech LDD 64, 144, 384 kbit/s LCD 64, 144, 384 kbit/s UDD 8, 64, 144, 384 50 % speech + 50 % UDD 8 50 % speech + 50 % UDD 384	Outdoor to Indoor and Pedestrian A & B	Microcell	X	X

(continued)

Table 1.2 - List of Tests configurations (concluded)

Test environment	Service mixture	Propagation model	Cell coverage	Link level Coverage efficiency	System level Spectrum efficiency
Outdoor to Indoor and Pedestrian 50 km/h	Speech LDD 64, 144, 384 kbit/s LCD 64, 144, 384 kbit/s UDD 8, 64, 144, 384 50 % speech + 50 % UDD 8 50 % speech + 50 % UDD 384	Vehicular A	Macrocell	X	X
Mixed cell Pedestrian/Vehicular 3 km/h for pedestrian 120 km/h for vehicles	Speech LDD 64, 144, 384 kbit/s LCD 64, 144, 384 kbit/s UDD 8, 64, 144, 384 50 % speech + 50 % UDD 8 50 % speech + 50 % UDD 384	Vehicular A for macrocell Outdoor to Indoor and Pedestrian A & B for microcell	Macrocell Microcell		X
Indoor 3 km/h	Speech LDD 144, 384, 2048 kbit/s LCD 144, 384, 2048 kbit/s UDD 8, 144, 384, 2048 50 % speech + 50 % UDD 8 50 % speech + 50 % UDD 2048	Indoor A & B	Picocell	X	X
Indoor (Low range outdoor) 3 km/h	Speech LDD 144, 384, 2048 kbit/s LCD 144, 384, 2048 kbit/s UDD 2048 kbit/s	Outdoor to Indoor and Pedestrian A	Microcell with penetration	X	

NOTE 1: In the case of mix services, the percentage represents the percentages of users, i.e. 50% of speech users and 50% of UDD users. This service mixture is to be used only for system simulations, but not for link level simulations for which services have to be evaluated independently.

NOTE 2: The coverage efficiency is to be evaluated for all circuit switched services in all environments using the simplified link budget template, and for at least on bearer service per environment using the alternative approach by system simulations (see section 1.6.3).

NOTE 3: The speed value specified for each Test environment is to be used to simulate the doppler effect in link level simulations.

NOTE 4: In order to reduce simulation times, the BER threshold may be relaxed to 10^{-4} for circuit switched data bearer services, except for the test cases needed for submission to REVAL.

B.1.3 Test Environment Descriptions

A central factor of mobile radio propagation environments is multi-path propagation causing fading and channel time dispersion. The fading characteristics vary with the propagation environment and its impact on the communication quality (i.e. bit error patterns) is highly dependent on the speed of the mobile station relative to the serving base station. These environments are described in Recommendation ITU-R M.1034.

The purpose of the test environments is to challenge the RTTs. Instead of constructing propagation models for all possible UMTS operating environments, a smaller set of test environments is defined which adequately span the overall range of possible environments. The descriptions of these test environments may therefore not correspond with those of the actual operating environments.

This section will identify the propagation model for each test operating environment listed below. For practical reasons, these test operating environments are an appropriate subset of the UMTS operating environments described in Recommendation ITU-R M.1034. While simple models are adequate to evaluate the performance of individual radio links, more complex models are needed to evaluate the overall system-level reliability and suitability of specific technologies. For narrowband technologies, time delay spread may be characterized by its r.m.s. value alone; for wideband technologies, however, the number, strength, and relative time delay of the many signal components become important. For some technologies (e.g. those employing power control) these models must include coupling between all co-channel propagation links to achieve maximum accuracy. Also, in some cases, the large-scale (shadow fading) temporal variations of the environment must be modelled.

The key parameters to describe each propagation model would include:

- i) time delay-spread, its structure, and its statistical variability (e.g. probability distribution of time delay spread);
- ii) geometrical path loss rule (e.g. R^{-4}) and excess path loss;
- iii) shadow fading;
- iv) multipath fading characteristics (e.g. Doppler spectrum, Rician vs. Rayleigh) for the envelope of channels; and,
- v) operating radio frequency.

Statistical models are proposed in section 1.2 to generate path losses and time delay structures for paths in each test environment.

It should be noted that UMTS will be a world-wide standard. Therefore, the models proposed for evaluation of RTTs should consider a broad range of environment characteristics, e.g. large and small cities, tropical, rural, and desert areas.

The following sections provide a brief description of the conditions that might be expected in the identified environments. The specific channel parameters are found in the appropriate parts of section 1.2.

UMTS may include both mobile wireless and fixed wireless applications. It should be noted that for the purpose of evaluation, operation in the fixed environment is considered to be covered by the mobile test environments. Generally, the fixed wireless channel model will be less complex due to lack of mobility. As a result, there is a trade-off possible between fixed and mobile users which should be considered while evaluating SRTTs.

B.1.3.1 Indoor Office Test Environment

This environment is also characterized by small cells and low transmit powers. Both base stations and pedestrian users are located indoors. Section B.1.2.2 describes the channel impulse response model and its parameters. The path loss rule varies due to scatter and attenuation by walls, floors, and metallic structures such as partitions and filing cabinets. These objects also produce shadowing effects. A log-normal shadow fading standard deviation of 12 dB can be expected. Fading ranges from Rician to Rayleigh, with Doppler frequency offsets set by walking speeds.

B.1.3.2 Outdoor to Indoor and Pedestrian Test Environment

This environment is characterized by small cells and low transmit power. Base stations with low antenna heights are located outdoors; pedestrian users are located on streets and inside buildings and residences. Section 1.2.2 describes the channel impulse response model. A geometrical path loss rule of R^{-4} is appropriate, but a wider range should be considered. If the path is a line of sight on a canyon-like street, for example, the path loss follows a R^{-2} rule where there

is Fresnel zone clearance. For the region where there is no longer Fresnel zone clearance, a path loss rule of R^{-4} is appropriate but a range up to R^{-6} may be encountered due to trees and other obstructions along the path. Log-normal shadow fading with a standard deviation of 10 dB is reasonable for outdoors and 12 dB for indoor. Building penetration loss averages 12 dB with a standard deviation of 8 dB. Rayleigh and/or Rician fading rates are generally set by walking speeds, but faster fading due to reflections from moving vehicles is occasionally seen.

B.1.3.3 Vehicular Test Environment

This environment is characterized by larger cells and higher transmit power. Assuming limited spectrum, higher cell capacity will be important. Section 1.2.2 describes the channel impulse response model and its parameters. A geometrical path loss rule of R^{-4} and log-normal shadow fading with 10 dB standard deviation are appropriate in urban and suburban areas. In rural areas with flat terrain the path loss is lower than that of urban and suburban areas. In mountainous areas, if path blockage are avoided by choosing base station locations, a path loss rule closer to R^{-2} may be appropriate. Rayleigh fading rates are set by vehicle speeds. Lower fading rates are appropriate for applications employing stationary terminals.

B.1.3.4 Mixed Test Environment

It is not sufficient for a SRTT to have good performance in only one of the specified test environments defined in this section. The SRTT should also have a good performance in a mixed environment, see Recommendation ITU-R M.1035, section 10. For example, it can be a “vehicular test environment” (macro cells) and an “outdoor to indoor test environment” (micro cells) in the same geographical area. In this area fast moving terminals (vehicles) should probably be connected to the macro cells to reduce the handoff rate (number of hand-offs per minute) and slow moving terminals (pedestrians) should be connected to the micro cells to achieve high capacity.

B.1.4 Propagation Models

The following sections provide both path loss models and channel impulse response models for the terrestrial component.

For the terrestrial environments, the propagation effects are divided into three distinct types of model. These are mean path loss, slow variation about the mean due to shadowing and scattering, and the rapid variation in the signal due to multipath effects. Equations are given for mean path loss for each of the three terrestrial environments. The slow variation is considered to be log-normally distributed. This is described by the standard deviation (given in the deployment model section).

Finally, the rapid variation is characterized by the channel impulse response. Channel impulse response is modelled using a tapped delay line implementation. The characteristics of the tap variability is characterized by the Doppler spectrum. A detailed treatment of the propagation models is found in Appendix 1.

B.1.4.1 Path Loss Models

Equations are given for mean path loss as a function of distance for each of the terrestrial environments except the mixed-cell test environment. The slow variation is considered to be log-normally distributed. This is described by the standard deviation expressed in dB and the decorrelation length of this long-term fading for the vehicular test environment.

B.1.4.1.1 Path Loss Model for Indoor Office Test Environment

The indoor path loss model expressed in dB is in the following simplified form, which is derived from the COST 231 indoor model presented in Appendix 1. This low increase of path loss versus distance is a worst-case from the interference point of view:

$$L = 37 + 30 \text{Log}_{10}(R) + 18.3 n^{((n+2)/(n+1)-0.46)}$$

where:

R is the transmitter-receiver separation given in metres;

n is the number of floors in the path.

NOTE: L shall in no circumstances be less than free space loss. A log-normal shadow fading standard deviation of 12 dB can be expected.

B.1.4.1.2 Path Loss Model for Outdoor to Indoor and Pedestrian Test Environment

The following model should be used for the outdoor to indoor and pedestrian test environment:

$$L = 40 \text{Log}_{10}(R) + 30 \text{Log}_{10}(f) + 49$$

where:

R is the base station - mobile station separation in kilometres;

f is the carrier frequency of 2000 in MHz for UMTS band application.

NOTE: L shall in no circumstances be less than free space loss. This model is valid for non-line-of-sight (NLOS) case only and describes worse case propagation. Log-normal shadow fading with a standard deviation of 10 dB for outdoor users and 12 dB for indoor users is assumed. The average building penetration loss is 12 dB with a standard deviation of 8 dB.

This model is to be used for coverage efficiency evaluation and simple capacity evaluation. A more detailed model is described hereafter in order to consider line of sight LOS and non line of sight NLOS situations. This model is to be used for spectrum efficiency evaluations in urban environments modelled through a Manhattan-like structure (see section 1.3), in order to properly evaluate the performance of RTTs in microcell situations that will be common in european cities at the time of UMTS deployment.

The proposed model is a recursive model², that calculates the path loss as a sum of LOS and NLOS segments. The shortest path along streets between the BS and the MS has to be found within the Manhattan environment.

The path loss in dB is given by the well-known formula $L = 20 \cdot \log_{10} \frac{4\pi d_n}{\lambda}$,

where d_n is the "illusory" distance,

λ is the wavelength,

n is the number of straight street segments between BS and MS (along the shortest path).

The illusory distance is the sum of these street segments and can be obtained by recursively using the expressions $k_n = k_{n-1} + d_{n-1} \cdot c$ and $d_n = k_n \cdot s_{n-1} + d_{n-1}$ where c is a function of the angle of the street crossing. For a 90 degree street crossing the value c should be set to 0.5. Further, s_{n-1} is the length in meters of the last segment. A segment is a straight path. The initial values are set according to: k_0 is set to 1 and d_0 is set to 0. The illusory distance is obtained as the final d_n when the last segment has been added.

The model is extended to cover the micro cell dual slope behaviour, by modifying the expression to :

² J.E. Berg, "A recursive Method For Street Microcell Path Loss Calculations", PIMRC '95, Vol 1, pp 140-143

$$L = 20 \cdot \log_{10} \left(\frac{4\pi d_n}{\lambda} \cdot D \left(\sum_{j=1}^n s_{j-1} \right) \right) \text{ where } D(x) = \begin{cases} x / x_{br}, & x > x_{br} \\ 1, & x \leq x_{br} \end{cases}$$

Before the break point x_{br} the slope is 2, after the break point it increases to 4. The break point x_{br} is set to 300 m. x is the distance from the transmitter to the receiver.

To take into account effects of propagation going above roof tops it is also needed to calculate the pathloss according to the shortest geographical distance. This is done by using the commonly known COST Walfish-Ikegami Model and with antennas below roof tops :

$$L = 24 + 45 \log(d+20)$$

where d is the shortest physical geographical distance from the transmitter to the receiver in metres.

The final pathloss value is the minimum between the path loss value from the propagation through the streets and the path loss based on the shortest geographical distance :

$$\text{Pathloss} = \min(\text{manhattan pathloss}, \text{macro path loss})$$

NOTE 1 : This pathloss model is valid for microcell coverage only with antenna located below roof top. In case the urban structure would be covered by macrocells, the former pathloss model should be used.

B.1.4.1.3 Path Loss Model for Vehicular Test Environment

This model, based on the same general format as in section 1.2.1.2, is applicable for the test scenarios in urban and suburban areas outside the high rise core where the buildings are of nearly uniform height.

$$L = 40(1 - 4 \times 10^{-3} \Delta h_b) \text{Log}_{10}(R) - 18 \text{Log}_{10}(\Delta h_b) + 21 \text{Log}_{10}(f) + 80 \text{ dB.}$$

Where:

R is the base station - mobile station separation in kilometres;

f is the carrier frequency of 2000 MHz;

Δh_b is the base station antenna height, in metres, measured from the average rooftop level.

To quantitatively evaluate each SRTT, the base station antenna height is fixed at 15 metres above the average rooftop ($\Delta h_b = 15$ m). Each proponent has an option to specify an alternate base station antenna height to optimize coverage and spectrum efficiency in their proposal.

Considering a carrier frequency of 2000 Mhz and a base station antenna height of 15 metres, the formula becomes :

$$L = 128.1 + 37.6 \text{Log}_{10}(R)$$

NOTE 1: L shall in no circumstances be less than free space loss. This model is valid for NLOS case only and describes worse case propagation. Log-normal shadow fading with 10 dB standard deviation are assumed in both urban and suburban areas.

NOTE 2: The path loss model is valid for a range of Δh_b from 0 to 50 metres.

B.1.4.1.4 Decorrelation Length of the Long-term Fading

The long-term (Log-Normal) fading in the logarithmic scale around the mean path loss L dB is characterized by a Gaussian distribution with zero mean and standard deviation. Due to the slow fading process versus distance Δx , adjacent fading values are correlated. Its normalized autocorrelation function $R(\Delta x)$ can be described with sufficient accuracy by an exponential function³.

³ Gudmundson, M., "Correlation Model for Shadow Fading in Mobile Radio Systems," Electronics Letters, vol. 27, November 7, 1991, No 23, pp. 2145-2146

$$R(\Delta x) = e^{-\frac{|\Delta x|}{d_{cor}} \ln 2}$$

with the decorrelation length d_{cor} , which is dependent on the environment. This concept can be applied in the vehicular test environment with a decorrelation length of 20 metres.

Although the evaluation of decorrelation length may not be fully valid in the Outdoor to Indoor and Pedestrian environment, this concept is still to be applied with a decorrelation length of 5 metres. This ensures that all systems are evaluated using the same shadowing model. For the indoor environment, a decorrelation length of 5 meters should be used.

B.1.4.2 Channel Impulse Response Model

For each terrestrial test environment, a channel impulse response model based on a tapped-delay line model is given. The model is characterized by the number of taps, the time delay relative to the first tap, the average power relative to the strongest tap, and the Doppler spectrum of each tap. A majority of the time, r.m.s. delay spreads are relatively small, but occasionally, there are "worst case" multipath characteristics that lead to much larger r.m.s. delay spreads. Measurements in outdoor environments show that r.m.s. delay spread can vary over an order of magnitude, within the same environment. Although large delay spreads occur relatively infrequently, they can have a major impact on system performance. To accurately evaluate the relative performance of candidate RTTs, it is desirable to model the variability of delay spread as well as the "worst case" locations where delay spread is relatively large.

As this delay spread variability cannot be captured using a single tapped delay line, up to two multipath channels are defined for each test environment. Within one test environment channel A is the low delay spread case that occurs frequently, channel B is the median delay spread case that also occurs frequently. Each of these two channels is expected to be encountered for some percentage of time in a given test environment. Table 1.2.2.0 gives percentage of time the particular channel may be encountered with the associated r.m.s. average delay spread for channel A and channel B for each terrestrial test environment.

Table 1.2.2.0: Parameters for Channel Impulse Response Model

Test Environment	r.m.s. A (ns)	P(A) (%)	r.m.s. B (ns)	P(B) (%)
Indoor Office	35	50	100	45
Outdoor to Indoor and Pedestrian	45	40	750	55
Vehicular - High Antenna	370	40	4000	55

The following tables describe the tapped-delay-line parameters for each of the terrestrial test environments. For each tap of the channels three parameters are given: the time delay relative to the first tap, the average power relative to the strongest tap, and the Doppler spectrum of each tap. A small variation, $\pm 3\%$, in the relative time delay is allowed so that the channel sampling rate can be made to match some multiple of the link simulation sample rate.

Table 1.2.2.1: Indoor Office Test Environment Tapped-Delay-Line Parameters

Tap	Channel A		Channel B		Doppler Spectrum
	Rel. Delay (nsec)	Avg. Power (dB)	Rel. Delay (nsec)	Avg. Power (dB)	
1	0	0	0	0	FLAT
2	50	-3.0	100	-3.6	FLAT
3	110	-10.0	200	-7.2	FLAT
4	170	-18.0	300	-10.8	FLAT
5	290	-26.0	500	-18.0	FLAT
6	310	-32.0	700	-25.2	FLAT

Table 1.2.2.2: Outdoor to Indoor and Pedestrian Test Environment Tapped-Delay-Line Parameters

Tap	Channel A		Channel B		Doppler Spectrum
	Rel. Delay (nsec)	Avg. Power (dB)	Rel. Delay (nsec)	Avg. Power (dB)	
1	0	0	0	0	CLASSIC
2	110	-9.7	200	-0.9	CLASSIC
3	190	-19.2	800	-4.9	CLASSIC
4	410	-22.8	1200	-8.0	CLASSIC
5	-	-	2300	-7.8	CLASSIC
6	-	-	3700	-23.9	CLASSIC

Table 1.2.2.3: Vehicular Test Environment, High Antenna, Tapped-Delay-Line Parameters

Tap	Channel A		Channel B		Doppler Spectrum
	Rel. Delay (nsec)	Avg. Power (dB)	Rel. Delay (nsec)	Avg. Power (dB)	
1	0	0.0	0	-2.5	CLASSIC
2	310	-1.0	300	0	CLASSIC
3	710	-9.0	8900	-12.8	CLASSIC
4	1090	-10.0	12900	-10.0	CLASSIC
5	1730	-15.0	17100	-25.2	CLASSIC
6	2510	-20.0	20000	-16.0	CLASSIC

B.1.5 Antenna patterns for sectorisation

This section defines typical antenna pattern (from GSM networks) to be used in case of sectorized antenna deployment. Only the horizontal pattern diagram is considered and a typical pattern corresponding to a main sector of 90 degrees is proposed. Pattern tables specify the gain for each degree. The gain has to be selected according to the angle between the antenna pointing direction and the mobile-base station direction.

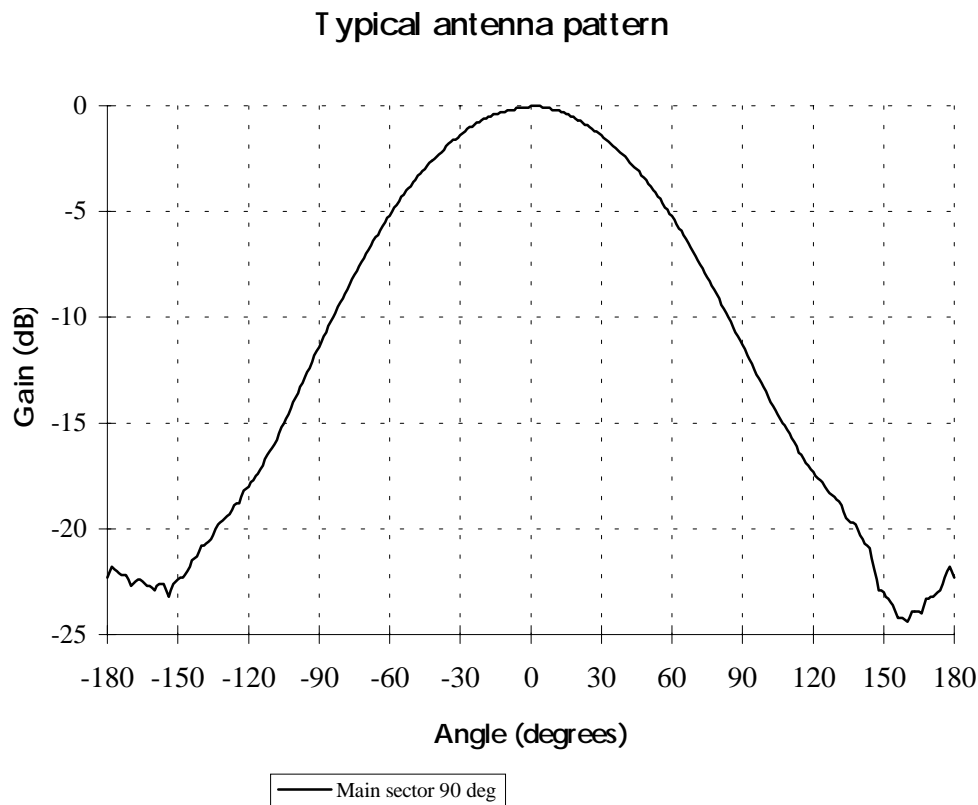

Figure 1.5.1: Horizontal antenna pattern

B.1.6 Link Budget Template and Deployment Models

In the sections that follow a link budget template and deployment models are proposed to be used for evaluation in each of the terrestrial test environments.

For the terrestrial SRTTs, the deployment models are used to extract critical parameters, such as coverage efficiency and spectrum efficiency. They also give a general idea of the amount of infrastructure required to provide service to the specified model deployment area.

The spectrum efficiency is defined in Erlangs/cell/MHz or kbit/s/cell/MHz for speech and in kbit/s/cell/MHz for data services.. Spectrum efficiency is dependent on the frequency bandwidth allocation and is not linearly scaleable between different bandwidth allocations. For the purpose of evaluation, a duplex bandwidth of 30 MHz is assumed and is to be divided between forward and reverse link as required by the SRTT implementation. An indication of the guardband needed between operators using the same SRTT should be given by the SRTT proponent.

The coverage efficiency is defined as the total number of cell sites per square kilometre required to meet the coverage requirements specified for each test environment. Coverage efficiency is to be calculated at low traffic levels (as specified in deployment tables) since the system will most probably be interference limited at high traffic load.

A specific deployment scenario is given for each terrestrial test environment. This contains information on market requirements including grade of service, traffic level, coverage requirements and subscriber penetration. Also given for each deployment scenario are the physical parameters of that environment which includes: area to cover, population density, and mobile terminal velocity (for Doppler frequency).

Along with a link budget template for each terrestrial test environment a deployment model results matrix is to be completed for each specified traffic. The results matrix is found in Table 1.3.3. The simulations used to complete the link budget template are required to complete the model deployment for each test environment. Each system proponent must use only the propagation models given in section 1.2 of this document.

System proponents will assume a centre frequency of 2.0 GHz when completing the deployment models.

B.1.6.1 Terrestrial Link Budget Templates

The link budget template shall be completed for both the forward and reverse links for each test environment and each test case service in Table 1.0. In the case of the mixed environment, the link budget template should be completed for the pedestrian and vehicular test environments. The link budget template should not be considered as a tool for planning since essential parts are missing such as body loss, penetration loss into cars etc. To facilitate comparable results SRTT independent parameters are pre-set.

Link level simulations based on channels A and B of the impulse response models are used to determine the required $E_b/(N_0+I_0)$ and hence the required C/I of their SRTT to meet the performance criteria given in Table 1.0. For calculations of coverage efficiencies, the worst case among channels A and B has to be assumed, but link level results should be given for both cases. Path loss formulas are then used to determine the maximum range and the coverage area. In case of hexagonal deployment of sectored cells, the area covered by one sector is defined as

$S = 3\sqrt{3} x \left(\frac{R}{2}\right)^2 / 2$, where R is the range obtained in the link budget. This means that the sectors are hexagonal with

base stations placed in the corners of the hexagons. Coverage efficiency is to be evaluated with tri-sectored antennas for macrocells and with omnidirectional antennas for microcells and picocells coverages.

Implementation independent parameters (*ii*) are fixed in the link budget template to avoid divergence not directly related to radio technology differences. The proponents must provide coverage efficiency values using these fixed *ii* values. Implementation dependent and independent link budget items are indicated by *id* and *ii* in the template.

An infrastructure is determined by the proponent to meet the service objectives and coverage requirements for the deployment. Calculation of coverage efficiency is done based on the proposed deployment for the given low traffic levels.

Table 1.3: Link Budget Template

id/ii	Item	Forward Link	Reverse Link
	Test environment		
	Test service		
	Multipath Channel Class	A, B	A, B
ii/id	(a0) Average Transmitter Power per traffic Channel (Note 1)	dBm	dBm
id	(a1) Maximum Transmitter Power per traffic Channel	dBm	dBm
id	(a2) Maximum Total Transmitter Power	dBm	dBm
ii	(b) Cable, connector, and combiner losses (enumerate sources)	2 dB	0 dB
ii	(c) Transmitter Antenna gain	13 dBi vehicular 10 dBi pedestrian 2 dBi indoor	0 dBi
id	(d1) Transmitter e.i.r.p. per traffic channel = (a1-b+c)	dBm	dBm
id	(d2) Total Transmitter e.i.r.p. = (a2-b+c)	dBm	dBm
ii	(e) Receiver Antenna Gain	0 dBi	13 dBi vehicular 10 dBi pedestrian 2 dBi indoor
ii	(f) Cable and Connector Losses	0 dB	2 dB
ii	(g) Receiver Noise Figure	5 dB	5 dB
ii	(h) Thermal Noise Density (H) (linear units)	-174 dBm/Hz 3.98×10^{-18} mW/Hz	-174 dBm/Hz 3.98×10^{-18} mW/Hz
id	(i) Receiver Interference Density (Note 2) (l) (linear units)	dBm/Hz mW/Hz	dBm/Hz mW/Hz
id	(j) Total Effective Noise plus Interference Density = $10 \log (10^{((g+h)/10)} + l)$	dBm/Hz	dBm/Hz
ii	(k) Information Rate (10 log (Rb))	dBHz	dBHz
id	(l) Required Eb/(No+lo)	dB	dB
id	(m) Receiver sensitivity = (j+k+l)		
id	(n) Hand-off gain	dB	dB
id	(o) Explicit diversity gain	dB	dB
id	(o') Other gain	dB	dB
id	(p) Log-normal fade margin	dB	dB
id	(q) Maximum path loss = {d1-m+(e-f)+o+n+o' -p}	dB	dB
id	(r) Maximum Range	m	m

Notes to Table 1.3:

NOTE 1: Proponents must provide coverage and spectrum efficiencies values using the following proposed average transmitter power per traffic channel. However they should provide additional values based on optimized transmitter power for their proposed SRTT.

	Forward Link	Reverse Link
(a0) Average Transmitter Power per traffic Channel	30 dBm vehicular 20 dBm pedestrian 10 dBm indoor	24 dBm vehicular 14 dBm pedestrian 4 dBm indoor

NOTE 2: Since the significance and method of calculating this value will vary from SRTT to SRTT, the proponent must give a detailed explanation of their method for calculating this value and its significance in determining capacity and coverage of the SRTT. In particular, the proponent must state explicitly what frequency reuse ratio and traffic loading per sector are assumed in determining this quantity. Interference has to be evaluated for the specified low traffic level given for each test environment.

The following sections provide descriptions of the individual link budget template items. Descriptions apply to both forward and reverse links unless specifically stated otherwise. For the forward link the base station is the transmitter and the mobile station the receiver. For the reverse link the mobile station is the transmitter and the base station the receiver.

(a0) Average Transmitter Power Per Traffic Channel (dBm)

The average transmitter power per traffic channel is defined as the mean of the total transmitted power over an entire transmission cycle with maximum transmitted power when transmitting.

(a1) Maximum Transmitter Power Per Traffic Channel (dBm)

Maximum transmitter power per traffic channel is defined as the total power at the transmitter output for a single traffic channel. A traffic channel is defined as a communication path between a mobile station and a base station used for user and signalling traffic. The term traffic channel implies a forward traffic channel and reverse traffic channel pair.

(a2) Maximum Total Transmitter Power (dBm)

Maximum total transmit power is the aggregate maximum transmit power of all channels.

(b) Cable, Connector, and Combiner Losses (Transmitter) (dB)

These are the combined losses of all transmission system components between the transmitter output and the antenna input (all losses in positive dB values). The value is fixed in the template.

(c) Transmitter Antenna Gain (dBi)

Transmitter antenna gain is the maximum gain of the transmitter antenna in the horizontal plane (specified as dB relative to an isotropic radiator). The value is fixed in the template.

(d1) Transmitter e.i.r.p. Per Traffic Channel (dBm)

This is the summation of transmitter power output per traffic channel (dBm), transmission system losses (-dB), and the transmitter antenna gain (dBi), in the direction of maximum radiation.

(d2) Transmitter e.i.r.p. (dBm)

This is the summation of the total transmitter power (dBm), transmission system losses (-dB), and the transmitter antenna gain (dBi).

(e) Receiver Antenna Gain (dBi)

Receiver antenna gain is the maximum gain of the receiver antenna in the horizontal plane (specified as dB relative to an isotropic radiator).

(f) Cable, Connector, and Splitter Losses (Receiver) (dB)

These are the combined losses of all transmission system components between the receiving antenna output and the receiver input (all losses in positive dB values). The value is fixed in the template.

(g) Receiver Noise Figure (dB)

Receiver noise figure is the noise figure of the receiving system referenced to the receiver input. The value is fixed in the template.

(h), (H) Thermal Noise Density, N_0 (dBm/Hz)

Thermal noise density, N_0 , is defined as the noise power per Hertz at the receiver input. Note that (h) is logarithmic units and (H) is linear units. The value is fixed in the template.

(i), (I) Receiver Interference Density (I_0 (dBm/Hz))

Receiver interference density is the interference power per Hertz at the receiver front end. This is the in-band interference power divided by the system bandwidth. The in-band interference power consists of both co-channel interference as well as adjacent channel interference. Thus, the receiver and transmitter spectrum masks must be taken into account. Note that (i) is logarithmic units and (I) is linear units. Receiver interference density I_0 for forward link is the interference power per Hertz at the mobile station receiver located at the edge of coverage, in an interior cell.

(j) Total Effective Noise Plus Interference Density (dBm/Hz)

Total effective noise plus interference density (dBm/Hz) is the logarithmic sum of the receiver noise density and the receiver noise figure and the arithmetic sum with the receiver interference density, i.e. $j = 10 \text{ Log} (10^{((g+h)/10)} + I)$

(k) Information Rate (10Log(Rb)) (dBHz)

Information rate is the channel bit rate in (dBHz); the choice of Rb must be consistent with the Eb assumptions.

(l) Required Eb/(No+Io) (dB)

The ratio between the received energy per information bit to the total effective noise and interference power density needed to satisfy the quality objectives specified in Table 1.0 under condition of section 1.2.2 channel model. Power control should not exceed the ceiling established by the sum of the log-normal fade margin plus hand-off gain. Note: Diversity gains included in the $E_b/(N_o + I_o)$ requirement should be specified here to avoid double counting. The translation of the threshold error performance to $E_b/(N_o + I_o)$ performance depends on the particular multipath conditions assumed.

(m) Receiver Sensitivity (j+k+l) (dBm)

This is the signal level needed at the receiver input that just satisfies the required Eb/(No+Io).

(n) Hand-off Gain/Loss (dB)

This is the gain/loss factor (+ or -) brought by hand-off to maintain specified reliability at the boundary. Assume equal average loss to each of the two cells. The handoff gain/loss shall be calculated for 50% shadowing correlation. The proponent must state explicitly the other assumptions made about hand-off in determining the hand-off gain.

(o) Explicit Diversity Gain (dB)

This is the effective gain achieved using diversity techniques. It should be assumed that the correlation coefficient is zero between received paths. Note: Diversity gain should not be double counted. For example, if the diversity gain is included in the $E_b/(N_o + I_o)$ specification, it should not be included here.

(o') Other Gain (dB)

An additional gain may be achieved due to future technologies. For instance, Space Diversity Multiple Access (SDMA) may provide an excess antenna gain. Assumptions made to derive this gain must be given by the proponent.

(p) Log-Normal Fade Margin (dB)

The log-normal fade margin is defined at the cell boundary for isolated cells. This is the margin required to provide a specified coverage availability over the individual cells.

(q) Maximum Path Loss (dB)

This is the maximum loss that permits minimum SRTT performance at the cell boundary.

$$\text{Max. path loss} = d1 - m + (e - f) + o + o' + n - p$$

(r) Maximum Range (km)

The maximum range is computed for each deployment scenario. Maximum range, R_{max} , is given by the range associated with the maximum path loss. The equations to determine path loss are given in section 1.2 of this document.

B.1.6.2 Low traffic levels for coverage efficiency evaluation

The coverage efficiency has to be evaluated for some specified traffic levels corresponding to a low network load, since the system will be most probably interference limited at high traffic loads.

This section defines some low traffic density levels in kbit/s/km², thus being independent of the service bit rate being used. For each test service, the user density is to be derived from these traffic density values, taking into account both the user bit rate and the channel activity factor :

$$\text{User density (Erlangs/km}^2\text{)} = \text{Traffic density} / (\text{User Bit Rate (kbit/s)} \cdot \text{Activity Factor})$$

Environment	Traffic density (kbit/s/km ²)	
	Indoor Office	kbit/s per floor
Outdoor to Indoor and Pedestrian	kbit/s per square km	outdoor : 1.44 indoor : 1.92
Vehicular	kbit/s per square km	0.35

NOTE: It is pointed out that these traffic density values have been derived from original low traffic densities in REVAL. However they have not been tested yet, and may then not correspond to 'low traffic levels' depending on the achieved range and system capacity. They may need to be revised once first coverage and capacity results will be obtained, but it is anyway important that all systems are evaluated using the same traffic values. For instance, they could be adjusted in order to correspond to 10 % of the network load at the averaged capacity limit.

B.1.6.3 Proposed methodology for coverage efficiency evaluation

First rough estimation of range can be made using the link budget template with link level simulations only. This provides results for noise limited systems assuming rough values for interference density, hand-off gain and diversity gain. The maximum range is obtained from the maximal pathloss value obtained in the link budget and using pathloss models given in section 1.2.

An alternative approach consists in using system simulations to determine coverage efficiency. This should be used in order to properly take into account interference density due to a specified traffic load and mobility effects.

For each Test environment, coverage efficiency should be evaluated assuming an hexagonal cell lay-out, with tri-sector antennas for macrocells (using the antenna pattern specified in section 1.5) and omnidirectional antennas for microcells and picocells, and using the pathloss models given in section 1.2. Traffic density has to be fixed according to the specified low traffic values, and the cell size has to be increased until the following coverage criteria is not longer met:

$$Probability (BER > BER_Threshold) < 5 \% \quad (\text{where } BER_Threshold \text{ refers to Table 1.0})$$

The maximal range is given by the distance between two base stations. Implementation independent (ii) parameters specified in the link budget template should be accounted for in simulations.

The maximal range should be evaluated for each circuit switched Test service since it will depend on the user bit rate.

For the indoor to outdoor and pedestrian environment, the range should be evaluated with the first pathloss model. For the indoor environment, the range could probably be evaluated using one floor only.

Note: For TDD refer to Annex D.

B.1.6.4 Deployment Model

This section defines the physical structure and mobility models for each Test environment, to be used for spectrum efficiency evaluation by system simulations.

A default deployment scheme is proposed for each Test environment in order to define common reference scenarios to allow comparison of systems under a same basis. Proponents can however provide additional spectrum efficiency values based on optimised deployment schemes according to their SRTT. The optimised scheme should then also be provided. Note: Annex D gives guidance on the approximation of deployment scenarios to finite area simulations.

User mobility has to be accounted for in spectrum efficiency evaluation, since it has a big impact on system performance. Handover needs then also to be modelled in dynamic system simulations. However, in order to avoid differences in results being due to the cleverness of the handover algorithm, it is proposed to use simple handover algorithms based on pathloss criteria. Proponents should describe the algorithm and relevant parameters being used in their evaluation. Results related to handover statistics should also be provided (number of handover per call, percentage of mobiles in macrodiversity, etc.).

B.1.6.4.1 Indoor Office Test Environment Deployment Model

This deployment scenario describes conditions relevant to the operation of a UMTS system that might be found in the indoor office test environment. The test service requirements for the indoor office environment are listed in Table 1.0. For this indoor deployment scenario a model office environment is specified below and consists of a large office building with an open floor plan layout. Office cubicles are separated by conducting moveable partitions. These partitions create a large degree in signal variation as is born out in the log-normal standard deviation given in Table 1.3.2.1.a. In this scenario users in elevators and stairwells are not considered though realistically they would have to be accounted for.

The specific assumptions about the indoor physical deployment environment are summarized in Table 1.3.2.1.b below.

Table 1.3.2.1.b: Indoor Office deployment model physical environment

Area per floor (m ²)	Number of floors	Room dimension	Log-Normal Standard Deviation (dB)	Mobile Velocity (km/h)
5000	3	10 x 10 x 3 m (room) 100 x 5 x 3 m (corridor)	12	3

The indoor model is illustrated on Figure 1.3.2.1.A together with a default deployment scheme, where base stations use omnidirectional antennas. For spectrum efficiency evaluation quality statistics should only be collected in the middle floor.

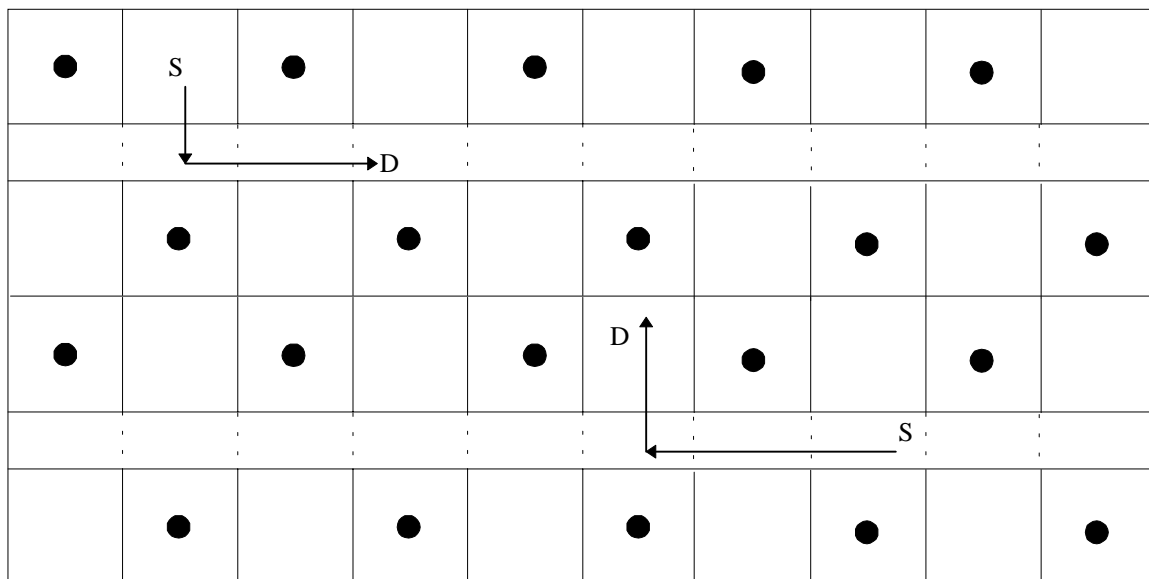

Figure 1.3.2.1.A: Indoor office model and deployment scheme

Mobility model

The mobility model is characterised as follows:

there are no mobility between the floors

mobiles are either stationary or moving with constant speed from an office room to corridor or vice versa.

if a mobile is in an office room, it has higher probability to be stationary

if a mobile is in the corridor, it has lower probability to be stationary

Each mobile is either in the stationary or the moving state. The transition from the stationary state to the moving state is random process. Time duration each mobile spends in the stationary state is drawn from the geometric (discrete exponential) distribution with different mean values depending whether the mobile is in an office room or in the

corridore. The transition from the moving state to the stationary state takes place when mobile reaches its destination. Figure 1.3.2.1.B illustrates the state transition.

When a mobile is in an office room and it is switched to the moving state it moves to the corridor, see Figure 1.3.2.1.A, according to the following procedure:

Select the destination co-ordinates in the corridor with uniform distribution. (Each place in the corridor has equal probability to become the destination point.)

The mobile 'walks' from its current location to the destination location so that first the vertical (y) co-ordinate is matched with the new co-ordinate and next the horizontal co-ordinate is matched with the destination co-ordinate. The speed is constant during the 'walking'.

When the mobile reaches the destination point it is transferred into the stationary state.

By letting mobiles simply walk straight out from the office room, it is simply assumed that the door dividing each office room and corridor is as wide as the office room itself. When a mobile is in a corridor and it is switched to the moving state it moves either to any of the office rooms with equal probability. The following 4 step procedure defines the movement along the corridor and from the corridor to an office room.

Select the destination office room by using discrete uniform distribution.

Select the destination co-ordinates with uniform distribution. (Each place in the corridor or in an office room has equal probability to become the destination point.)

The mobile 'walks' from its current location so that first the horizontal (x) co-ordinate is matched with the new co-ordinate and next the vertical (y) co-ordinate is matched with the destination co-ordinate. The speed is constant during the 'walking'.

When the mobile reaches the destination point it is transferred into the stationary state.

At the stationary state mobiles do not move at all.

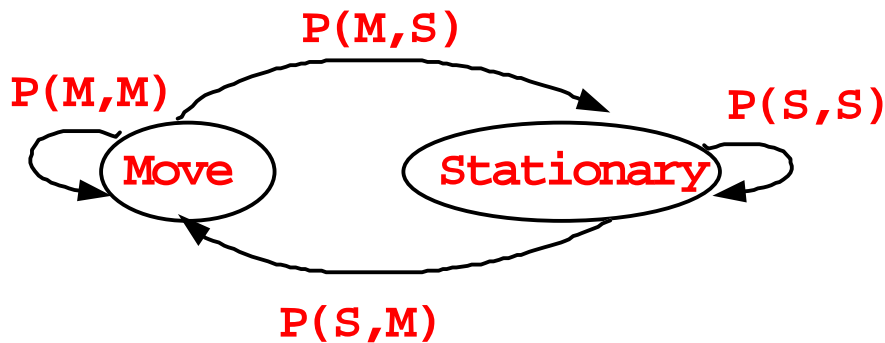

Figure 1.3.2.1.B: State automate presentation MS movement.

To derive transition probabilities from the stationary state to the move state the following parameters must be set: ratio of mobiles at office rooms (r), mean office room stationary time (mr) and iteration time step (Δt). With these parameters the transition probabilities per iteration time step ($1-\Delta t/mr$, $1-\Delta t/mc$) and mean corridor stationary time (mc) can be derived so that flow to the office rooms equals to the flow from the office rooms.

$$r \cdot \frac{\Delta t}{mr} = (1-r) \cdot \frac{\Delta t}{mc} ,$$

with the default parameters, enlisted in the table below, the following values are obtained.

$$P(S,S) \text{ in office room} = 1-0.005/30=0.999833$$

$$P(S,M) \text{ in office room} = 0.005/30=0.0001667$$

$$P(S,S) \text{ in corridor} = 1-0.0009444=0.9990556$$

$P(S,M)$ in office room = $0.005 \cdot 85 / (30 \cdot 15) = 0.0009444$

and average stationary time in the corridor becomes $\Delta t / P(S,M) = 5.294$ seconds.

The following table presents the default parameters for the indoor mobility model :

ratio of mobiles at office rooms	85%
mean office room stationary time	30 s
simulation time step	0.005 s
number of office rooms	40
mobile speed	3 km/h

B.1.6.4.2 Outdoor To Indoor and Pedestrian Deployment Model

The physical environment description includes only outdoor users, and is to be used for spectrum efficiency evaluation using system simulations. However in order to evaluate the indoor coverage provided by the outdoor base stations, an additional loss due to building penetration is to be taken into account in the link budget for coverage efficiency evaluation. Coverage figures for both outdoor and penetration should be provided.

The test service requirements for the outdoor to indoor pedestrian environment are listed in Table 1.0.

The specific assumptions about the outdoor physical deployment environment are summarized in Table 1.3.2.2.b below.

Table 1.3.2.2.b: Deployment model physical environment

Type	Building Penetration Loss/standard Deviation (dB)	Log-Normal Standard Deviation (dB)	Mobile Velocity (km/h)
Outdoor	NA	10	3
Indoor	12/8	12	3

A Manhattan-like structure is also defined for the Outdoor to Indoor and Pedestrian environment to be used together with the three slopes pathloss model being defined in section B.1.2.2. Parameters for this structure are defined in table 1.3.2.2.C and illustrated on Figure 1.3.2.2.A. A default deployment scheme is also proposed with base stations using omnidirectional antennas, and quality statistics should only be collected among cells marked with a T on the figure.

Area	Block size	Street width	Base station - mobile height difference
6.5 km ²	200 m x 200 m	30 m	10 m

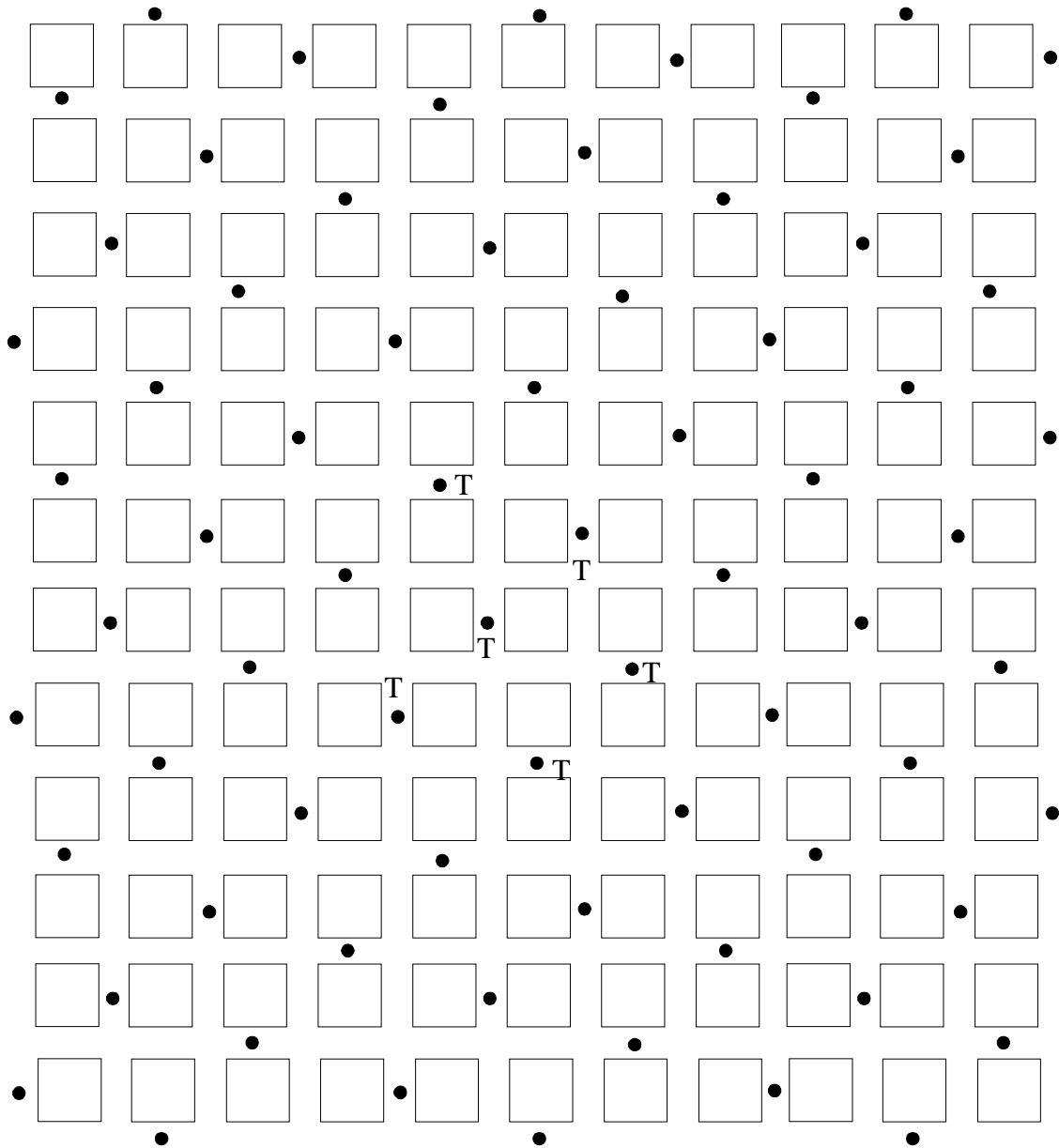

Figure 1.3.2.2.A: Manhattan-like urban model and deployment scheme

Mobility model

The urban mobility model is highly related to the Manhattan-like structure defined in Figure 1.3.2.2.A. In such a structure, mobiles move along streets and may turn at cross streets with a given probability. Mobile’s position is updated every 5 metres and speed can be changed at each position update according to a given probability. The mobility model is described by the following parameters: Mean speed : 3 km/h

Minimum speed: 0 km/h

Standard deviation for speed (normal distribution): 0.3 km/h

Probability to change speed at position update : 0.2

Probability to turn at cross street : 0.5

The turning probability is illustrated on the figure below :

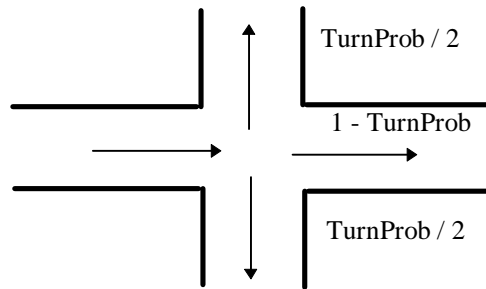

Mobiles are uniformly distributed in the street and their direction is randomly chosen at initialisation.

NOTE: It is pointed out that the Outdoor to Indoor and Pedestrian wideband propagation channel B may not be relevant for the Manhattan structure due to high delay spreads.

B.1.6.4.3 Vehicular Environment Deployment Model

The test service requirements for the vehicular environment are listed in Table 1.0. The cell radius is 2000 m for services up to 144 kbit/s and 500 m for services above 144 kbit/s. The base station antenna height must be above the average roof top height of 15 metres. The deployment scheme is assumed to be an hexagonal cell lay out with distances between base stations equal to 6 km (see Figure 1.5.4.3.A below). Tri-sectorised cells should be used with the antenna pattern being specified in section 1.5.

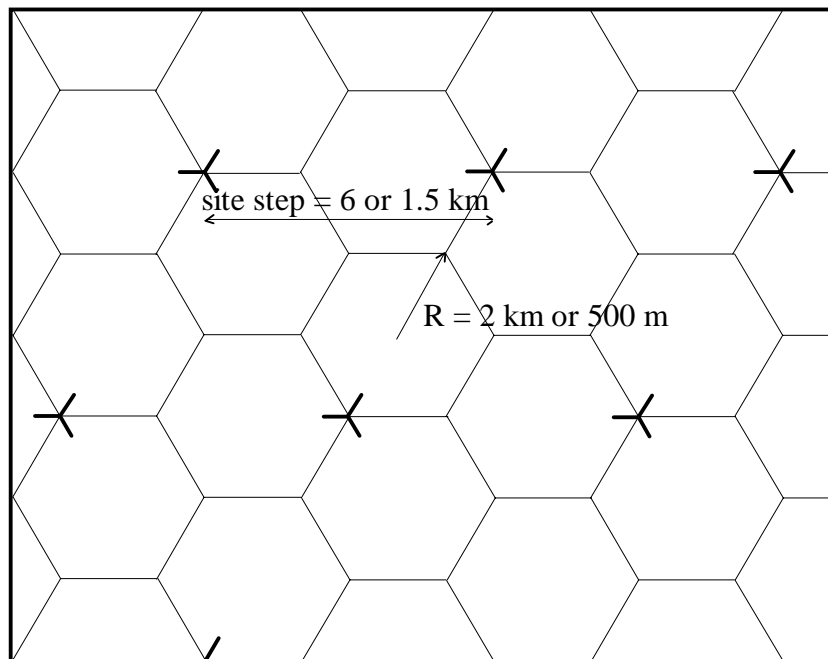

Figure 1.3.4.3.A - Vehicular model and proposed deployment scheme

The log-normal standard deviation for shadowing effects is assumed to be 10 dB.

Mobility model

The mobility model for the Vehicular Test environment is a pseudo random mobility model with semi-directed trajectories. Mobile's position is updated according to the decorrelation length (as defined in section 1.2.1.4), and direction can be changed at each position update according to a given probability. Direction can be changed within a given sector to simulate semi-directed trajectory.

Mobile's speed is constant and the mobility model is defined by the following parameters :

Speed value : 120 km/h

Probability to change direction at position update : 0.2

Maximal angle for direction update : 45°

Decorrelation length : 20 metres

Mobiles are uniformly distributed on the map and their direction is randomly chosen at initialisation.

In addition, proponents should provide information on how high speed up to 500 km/h can be handled, mainly by means of link level performance figures.

B.1.6.4.4 Mixed-cell Pedestrian/Vehicular Test Environment Deployment Model

This deployment scenario describes conditions relevant to the operation of a UMTS system that might be found in the mixed test environment. The physical environment consists in a urban area covered with microcells (with antenna below roof top) and overlaid by macrocells (with antenna above roof top). It can be considered as a mixture of Outdoor to Indoor and Vehicular Test environments. The surrounding open area covered by macrocells has to be large enough so that umbrella macrocells above the urban area are fully interfered by a full tier of co-channel interfering cells. An example is presented on figure 1.3.2.4.A below, together with a proposed default deployment scheme.

The test service requirements for the mixed-cell environment are listed in Table 1.0. The cell radius is same as defined for vehicular and pedestrian. The link budget uses the pedestrian and vehicular ones which have been calculated before. The interference from the large cells to the small cells and vice versa should be accounted for, if necessary.

The specific assumptions about the outdoor and vehicular physical deployment environment are summarized in Table 1.3.2.4.b below.

Table 1.3.2.4.b: Mixed test deployment model physical environment

Path loss Type	Log-Normal Standard Deviation (dB)	Mobile Velocity (km/h)	% users
Pedestrian (Outdoor)	10	3	60
Vehicular	10	80-120	40

Mobility model

Users move according to the Outdoor to Indoor and Pedestrian model in urban area, and according to the Vehicular mobility model in the open area.

Handover between macrocells and microcells are allowed for all users, but the handover strategy used in the evaluation has to be given. The whole bandwidth can be partitioned between macrocells and microcells as desired for the proposed system.

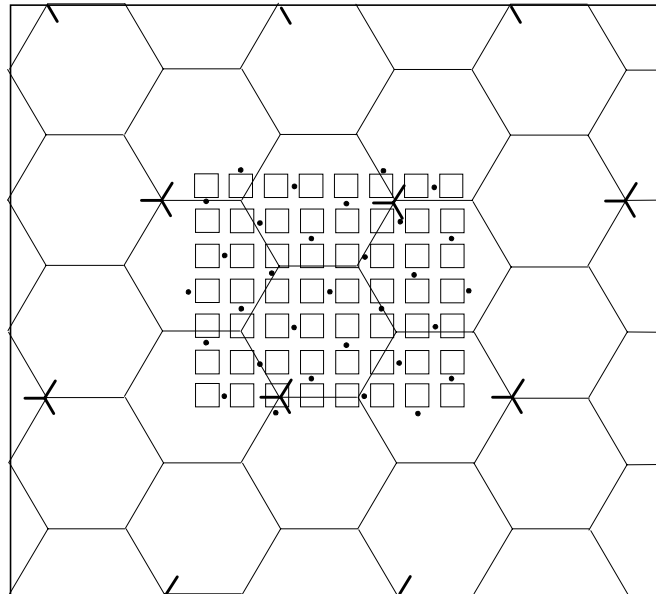

Figure 1.3.2.4.A: Mixed physical environment and proposed deployment model

B.1.6.5 Spectrum efficiency evaluation

This section presents the definition of system capacity to be used for spectrum efficiency evaluation, and a methodology to derive these figures using system simulations.

The proponent shall not only provide spectrum efficiency numbers, but also additional results, specified in Section B.1.6.5.6.

B.1.6.5.1 Active Session Throughput

The active session throughput, S , is defined as the ratio of correctly received user bits during the entire session and the session length excluding the time where there is nothing to transmit (i.e. empty buffer).

B.1.6.5.2 Satisfied user

For *circuit switched services*, we define a satisfied user as a user that have all three of the following constraints fulfilled:

1. The user do not get blocked when arriving to the system. If blocking is applied, the proponent must specify used blocking criteria.
2. The user have sufficiently good quality more than a certain time (fraction) of the session, i.e., $\text{Probability}(\text{BER} > \text{BER_Threshold}) < x_1 \%$
3. The user does not get dropped. A call is dropped if $\text{BER} > \text{BER_Threshold}$ more than t_{dropp1} seconds.

In order to get comparable results for good quality percentage, quality statistics have to be collected every t_1 seconds.

For *packet services*, we define a satisfied user as a user that have all three of the following constraints fulfilled:

1. The user do not get blocked when arriving to the system⁴. If blocking is applied, the proponent must specify used blocking criteria.
2. The active session throughput, S , of the session is equal to or greater than $S_{\text{threshold}}$.

⁴ The most common way of treating packet users is not to block them but to queue them. However, if the proponent applies some kind of admission control for packet users, there will exist a ratio of blocked packet users. Thus blocking of packet users, means that they are not put in a queue but entirely blocked from the system.

3. The user does not get dropped. If dropping is applied, the proponent must specify used dropping criteria.

NOTE: for TDD refer to Annex D

B.1.6.5.3 System Load

The system load, v , is measured in [kb/s/cell/MHz].

For circuit switched users, the system load, v_{cs} , is derived as follows:

$$v_{cs} = \omega_{cs} * \text{user_bitrate} * \text{activity_factor} / \text{system_bandwidth [kb/s/cell/MHz]},$$

where ω_{cs} is the average number of (simultaneous) circuit switched users per cell, i.e. the offered load (Erlangs).

System load for packet users, v_{pkt} , is derived as follows:

$$v_{pkt} = D/T/Cells/system_bandwidth [kb/s/cell/MHz],$$

where D is total number of correctly received user bits within the cells from where the statistics are collected

T is the simulation measuring time, defined as the time during the simulation when the statistics are collected

$Cells$ is the number of cells in the system from where the statistics are collected.

The system load is calculated separately for uplink and downlink respectively.

In the case of mixed services configurations, the system load is derived as:

$$v = \sum_{i=1}^{N_{cs}} v_{cs,i} + \sum_{i=1}^{N_{pkt}} v_{pkt,i}$$

where N_{cs} is the number of circuit switched services and N_{pkt} is the number of packet services.

B.1.6.5.4 Spectrum Efficiency

For single service scenarios, the spectrum efficiency, v^* , is defined as the system load where there are exactly x_2 % satisfied users.

In the case of mixed services configurations, there must be at least x_2 % satisfied users for each service independently.

The spectrum efficiency is defined as the system load where any of the services has exactly x_2 % satisfied users, whereas the rest of the services have at least x_2 % satisfied users each. This is exemplified in Figure 1.6.A.

The spectrum efficiency should be given separately for uplink and downlink respectively.

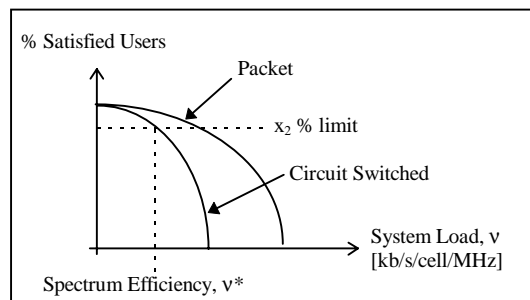

Figure 1.6.A: Example of spectrum efficiency for a mixed service scenario with one circuit switched service and one packet service.

B.1.6.5.5 Parameter values

In Table 1.6.A the values of the parameters previously mentioned are presented.

TABLE 1.6.A: Values of parameter in spectrum efficiency evaluation

Parameter	Name/Description	Value
x_1	“Bad quality probability threshold”	5 %
t_1	sampling time for quality statistics	0.5 second
t_{dropp1}	“Dropping time-out, circuit switched”	Max (5, 10/(bit rate . BER_threshold) seconds
$S_{\text{threshold}}$	“Active Session Throughput Threshold”	10% of the average bit rates in footnote of Table 1.1 ⁵ (i.e., $S_{\text{threshold}} = 0.8, 3.2, 6.4, 14.4, 38.4$ and 204.8 kbit/s for average bit rates of 8,32,64,144,384 and 2048 kbit/s respectively).
x_2	“Threshold for ratio of satisfied users”	98 %
BW	Bandwidth	30 MHz duplex

B.1.6.5.6 Required results

Within the spectrum efficiency evaluation the proponent shall, provide the following results for each test case:

1. Numerical value of the spectrum efficiency [kb/s/cell/MHz]
2. Numerical value for ratio of satisfied users for the case from where the spectrum efficiency value (in 1.) is obtained.
3. In case of UDD: Average active session throughput [kb/s], $mean(S)$, for the case from where the spectrum efficiency value (in 1.) is obtained.
4. In case UDD: A sample density function of the active session throughput values (per session) for the case from where the spectrum efficiency value (in 1.) is obtained. Such a sample density function is exemplified in Figure 1.6.B.

⁵ The values of the active session throughput thresholds are chosen to make it possible to perform re-transmission, queuing, etc. in order to make the packet services effective from a system point of view.

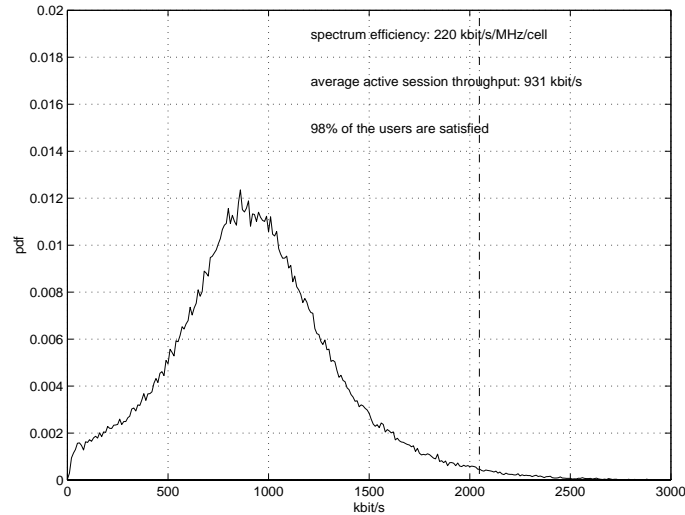

Figure 1.6.B - Example of a sample density function for UDD 2048.

B.1.6.6 Deployment Model Result Matrix

Results from the system deployment model are to be tabulated as specified below.

Table 1.3.3: Deployment model result matrix

Input Assumptions					
Test environment					
Test service mixture					
Total Number of cell sites					
Total bandwidth					
Base Station Antenna Height (m)					
Any other assumptions made by the proponent (e.g. antenna pattern, sectorization etc.)					
Deployment Results					
In addition to the results specified in Section 1.6.5.6, coverage vs. cell radius should also be presented.					

B.1.7 Guard band evaluation

This section defines a simple methodology to be used in order to evaluate guard bands between non-coordinated UMTS operators, and also between non-coordinated UMTS and GSM operators. This methodology is to be applied for a quick evaluation of required guard band, but may not provide very accurate values. It is pointed out that the ERC/TG1 group might develop more detailed methods based on Monte Carlo simulations, in order to get a more accurate evaluation of the required guard bands.

B.1.7.1 Scenarios for guard band evaluation

The only scenario which is studied here is the case on uncoordinated base stations, meaning that base stations from different operators are not co-sited. Operators are using adjacent frequency bands. The guard bands should be evaluated

for both TDD and FDD modes of UTRA, and also for GSM. The interference scenarios should consider coexistence of FDD and FDD, TDD and TDD, FDD and TDD, TDD and GSM and FDD and GSM. The different possible interference scenarios are depicted in Figure 1.7.1 below :

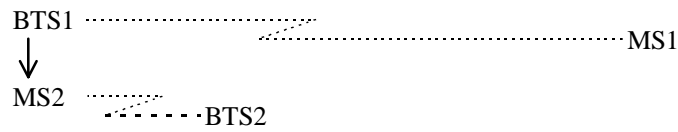

BS →MS interference scenario

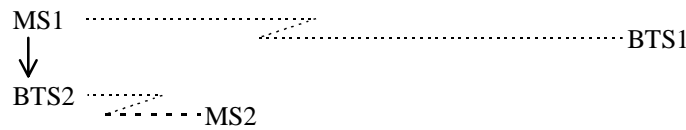

MS → BS interference scenario

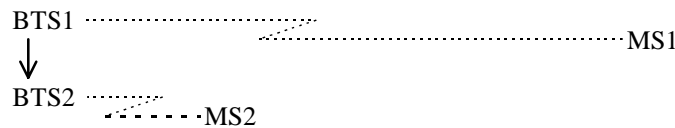

BS →BS interference scenario

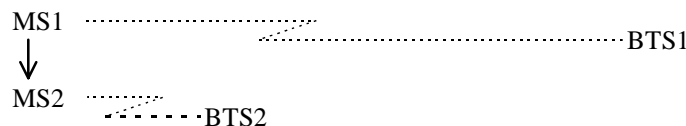

MS → MS interference scenario

Figure 1.7.1: Interference scenarios for uncoordinated base stations

It is pointed out that some interference scenarios may not be relevant depending on the modes being considered (for instance the BS to BS and MS to MS scenarios are not applicable when considering FDD modes).

B.1.7.2 Evaluation methodology

Guard band are evaluated according to the so-called Minimum Coupling Loss (MCL) methodology.

The Minimum Coupling Loss (MCL) represents the assumed minimum loss between a mobile and a base station belonging to non-coordinated cells. This value has to be evaluated according to the assumed physical minimal distance between between mobile and base station in each environment :

$$MCL (dB) = Pathloss (MinimalDistance(MS,BS) - AntennaGain + FeederLoss$$

At this coupling loss, the victim should have a 3 dB loss of sensitivity from interference generated by the non-coordinated mobile or base. This corresponds to an interference level at the receiver equal to the receiver noise floor.

Coupling losses are given by the two following formulas for uplink and downlink scenarios :

MS→BS interference scenario :

$$\begin{aligned}
 \text{[Coupling loss]} &= [\text{MS Tx noise in BS Rx bandwidth}] - [\text{BS sensitivity}] + [\text{BS C/I margin}] \\
 &+ [\text{multiple interferer margin}] \\
 &= [\text{MS Tx noise in BS Rx bandwidth}] - [\text{BS Interference level}] + [\text{multiple} \\
 &\text{interferer margin}] \\
 &= [\text{MS Tx noise in BS Rx bandwidth}] - ([\text{Thermal Noise density}] + [\text{Noise} \\
 &\text{bandwidth}] + [\text{BS Noise figure}]) + [\text{multiple interferer margin}];
 \end{aligned}$$

BS→MS interference scenario :

$$\begin{aligned}
 \text{[Coupling loss]} &= [\text{BS Tx noise in MS Rx bandwidth}] - [\text{MS sensitivity}] + [\text{MS C/I} \\
 &\text{margin}] + [\text{multiple interferer margin}] \\
 &= [\text{BS Tx noise in MS Rx bandwidth}] - [\text{MS Interference level}] + \\
 &[\text{multiple interferer margin}] \\
 &= [\text{BS Tx noise in MS Rx bandwidth}] - ([\text{Thermal Noise density}] + [\text{Noise} \\
 &\text{bandwidth}] + [\text{MS Noise figure}]) + [\text{multiple interferer margin}];
 \end{aligned}$$

MS→MS interference scenario :

$$\begin{aligned}
 \text{[Coupling loss]} &= [\text{MS Tx noise in MS Rx bandwidth}] - [\text{MS sensitivity}] + [\text{MS C/I} \\
 &\text{margin}] + [\text{multiple interferer margin}] \\
 &= [\text{MS Tx noise in BS Rx bandwidth}] - [\text{MS Interference level}] + \\
 &[\text{multiple interferer margin}] \\
 &= [\text{MS Tx noise in MS Rx bandwidth}] - ([\text{Thermal Noise density}] + \\
 &[\text{Noise bandwidth}] + [\text{MS Noise figure}]) + [\text{multiple interferer margin}];
 \end{aligned}$$

BS→BS interference scenario :

$$\begin{aligned}
 \text{[Coupling loss]} &= [\text{BS Tx noise in BS Rx bandwidth}] - [\text{BS sensitivity}] + [\text{BS C/I margin}] \\
 &+ [\text{multiple interferer margin}] \\
 &= [\text{BS Tx noise in BS Rx bandwidth}] - [\text{BS Interference level}] + [\text{multiple} \\
 &\text{interferer margin}] \\
 &= [\text{BS Tx noise in BS Rx bandwidth}] - ([\text{Thermal Noise density}] + [\text{Noise} \\
 &\text{bandwidth}] + [\text{BS Noise figure}]) + [\text{multiple interferer margin}];
 \end{aligned}$$

The multiple interferer margin represents the fact that several interferers can transmit close to the receiver's band. This value is difficult to assess, since interference is caused mainly but not only by the last channels, and the number of interferers also depends on the system. In GSM 05.50, it is recommended to take a margin of 10 dB for MS→BS. However, for these evaluations, a value of 0 dB is suggested for the multiple interference margin.

B.1.7.3 System parameters

The following system parameters are of major importance for the evaluation of guard bands. They should be given with the relevant justifications, according to the system specifications and the assumed implementation.

- MS and BS noise figures
- MS and BS assumed receiver filters and their noise bandwidth (the same filter should be used to calculate noise floor and received interference from the non-coordinated mobile/base station)
- Resulting receiver noise floor levels
- MS and BS transmitter powers
- MS and BS transmitter spectrum masks and assumptions for the masks (non-linearities, output power back-off, etc.). Spectrum masks prior and after power amplifier should be given.

B.1.7.4 Presentation of results

Guard bands have to be evaluated for the following cases :

- UMTS carrier located next to a non-coordinated UMTS carrier
- UMTS carrier located next to a non-coordinated GSM carrier

Results should be presented as plots of attenuation of an interfering carrier into a receiver as a function of carrier spacing between the two adjacent carriers (belonging to different operators) (see Figure 1.7.2 below).

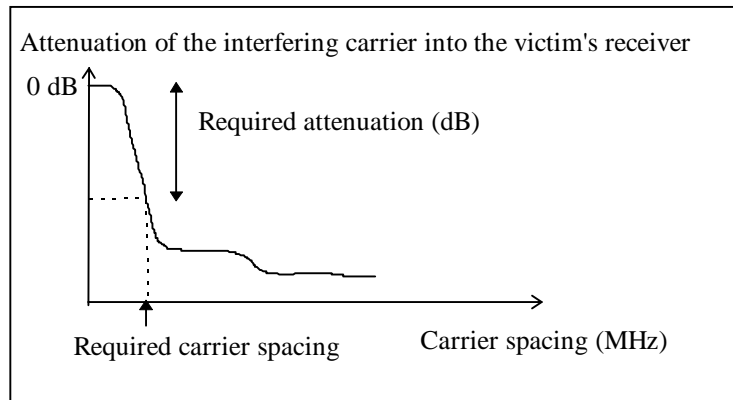

Figure 1.7.2 : Attenuation of interference as a function of carrier spacing

The effective guard band value can be evaluated assuming a given MCL value. Guard bands required for different systems can then be compared using common assumptions.

It is pointed out that the absolute values obtained with the MCL methodology may not be fully valid for the actual implementation of systems, but this simple methodology should permit to draw conclusions on the comparison between different radio interface options, as well as indicate rough estimates for required guard bands.

The methodology is a worst case scenario analysis, demonstrating the effect of a single interfering source. The impact of guard bands on system performance needs other methods of evaluation, such as Monte Carlo analysis. The MCL method is however useful to give a quick indication of the impact of the choice of guard bands.

B.1.8 Propagation Models

The following sections provide a more detailed treatment of both the path loss models, where more detail is available, and the channel impulse response models. The personal antenna height of 1.5 m is used in developing the propagation models for all test environments.

B.1.8.1 Path Loss Models

B.1.8.1.1 Path Loss Model for Indoor Office Test Environment

The indoor office path loss is based on the COST 231 model which is defined as follows⁶:

$$L = L_{FS} + L_c + \sum k_{wi} L_{wi} + n^{((n+2)/(n+1) - b)} * L_f$$

⁶ COST 231 Final Report, Commission of the European Communities.

where

L_{FS} = free space between transmitter and receiver

L_c = constant loss

k_{wi} = number of penetrated walls of type i

n = number of penetrated floors

L_{wi} = loss of wall type i

L_f = loss between adjacent floors

b = empirical parameters

NOTE 1: L_c normally is set to 37 dB.

NOTE 2: n=4 is an average for indoor office environment. For capacity calculations in moderately pessimistic environments, the model can be modified to n = 3.

Table 1.2.1: Weighted average for loss categories

Loss category	Description	Factor (dB)
L_f	Typical floor structures (i.e. offices) - hollow pot tiles - reinforced concrete - thickness typ. < 30 cm	18.3
L_{w1}	Light internal walls - plasterboard - walls with large numbers of holes (e.g. windows)	3.4
L_{w2}	Internal walls - concrete, brick - minimum number of holes	6.9

Under the simplifying assumptions of the office environment the indoor path loss model has the following form:

$$L = 37 + 30 \log_{10}(R) + 18.3 \cdot n^{((n+2)/(n+1) - 0.46)}$$

where:

R is the transmitter-receiver separation given in metres;

n is the number of floors in the path.

B.1.8.1.2 Path Loss Model for Outdoor to Indoor and Pedestrian Test Environment

The following model is intended for the outdoor to indoor and pedestrian test environment. In the general model for outdoor transmission loss, the total transmission loss L in decibels between isotropic antennas is expressed as the sum of free space loss, L_{fs} , the diffraction loss from rooftop to the street, L_{rts} , and the reduction due to multiple screen diffraction past rows of buildings, L_{msd} . In this model, L_{fs} and L_{rts} are independent of the base station antenna height, while L_{msd} is dependent on whether the base station antenna is at, below or above building heights. In general the model is given as:

$$L(d) = L_{fs} + L_{rts} + L_{msd}$$

Given a mobile-to-base separation R, the free space loss between them is given by:

$$L_{fs} = -10\text{Log}_{10}\left(\frac{\lambda}{4\pi d}\right)^2$$

The diffraction from the rooftop down to the street level gives the excess loss to the mobile station:

$$L_{rts} = -10\text{Log}_{10}\left[\frac{\lambda}{2\pi^2 r}\left(\frac{1}{\theta} - \frac{1}{2\pi + \theta}\right)^2\right]$$

where:

$$\theta = \tan^{-1}\left(\frac{|\Delta h_m|}{x}\right)$$

$$r = \sqrt{(\Delta h_m)^2 + x^2}$$

Δh_m is the difference between the mean building height and the mobile antenna height; x is the horizontal distance between the mobile and the diffracting edges.

For the general model, the multiple screen diffraction loss from the base antennas due to propagation past rows of buildings is:

$$L_{msd} = -10\text{Log}_{10}(Q_M^2)$$

where Q_M is a factor dependent on the relative height of the base station antenna as being either at, below or above the mean building heights^{7,8}.

In this case the base-station antenna height is near mean rooftop level, then:

$$Q_M = \frac{d}{R}$$

The total transmission loss for the near rooftop case then becomes:

$$L = -10\text{Log}_{10}\left(\frac{\lambda}{2\sqrt{2}\pi R}\right)^2 - 10\text{Log}_{10}\left[\frac{\lambda}{2\pi^2 r}\left(\frac{1}{\theta} - \frac{1}{2\pi + \theta}\right)^2\right] - 10\text{Log}_{10}\left(\frac{d}{R}\right)^2$$

When $\Delta h_b = -5$ m, $\Delta h_m = 10.5$ m, $x = 15$ m, and $b = 80$ m, as typical in an urban and suburban environment, the above path loss expression reduces to a simple function of the transmitter to receiver distance R (in kilometres) and frequency f (in MHz),

$$L = 40\text{Log}_{10}(R) + 30\text{Log}_{10}(f) + 49$$

Note: L shall in no circumstances be less than free space loss.

B.1.8.1.3 Path Loss Model for Vehicular Test Environment

This model, based on the same general format as in section B1.2.2, is applicable for the test scenarios in urban and suburban areas outside the high rise core where the buildings are of nearly uniform height.

In this case the base station antenna height is above rooftop level and:

⁷ Xia, H.H., and Bertoni, H.L., "Diffraction of Cylindrical and Plane Waves By an Array of Absorbing Half Screens," IEEE Transactions on Antennas and Propagation, Vol. 40, No. 2, February 1992, pp. 170-177.

⁸ Maciel, L.R., Bertoni, H.L., and Xia, H.H., "Unified Approach to Prediction of Propagation Over Buildings for All Ranges of Base Station Antenna Height," IEEE Transactions on Vehicular Technology, Vol. 42, No 1, February 1993, pp. 41-45.

$$Q_M = 2.35 \cdot \left(\frac{\Delta h_b}{d} \sqrt{\frac{b}{\lambda}} \right)^{0.9}$$

where:

Δh_b is the height difference between the base-station antenna and the mean building rooftop height.

b is the average separation between rows of buildings.

The total transmission loss for the above rooftop case then becomes:

$$L = -10 \log_{10} \left[\left(\frac{\lambda}{4\pi R} \right)^2 \right] - 10 \log_{10} \left[\frac{\lambda}{2\pi^2 r} \left(\frac{1}{\theta} - \frac{1}{2\pi + \theta} \right)^2 \right] - 10 \log_{10} \left[(2.35)^2 \left(\frac{\Delta h_b}{R} \sqrt{\frac{d}{\lambda}} \right)^{1.8} \right]$$

Measurements in building environments⁹ showed that the path loss slope is approximately a linear function of the base station antenna height relative to average rooftop Δh_b . The above path loss equation can then be modified as

$$L = -10 \log_{10} \left[\left(\frac{\lambda}{4\pi R} \right)^2 \right] - 10 \log_{10} \left[\frac{\lambda}{2\pi^2 r} \left(\frac{1}{\theta} - \frac{1}{2\pi + \theta} \right)^2 \right] - 10 \log_{10} \left[(2.35)^2 \left(\Delta h_b \sqrt{\frac{d}{\lambda}} \right)^{1.8} / R^{2(1-4 \cdot 10^{-3} \Delta h_b)} \right]$$

where:

$$\theta = \tan^{-1} \left(\frac{|\Delta h_m|}{x} \right)$$

$$r = \sqrt{(\Delta h_m)^2 + x^2}$$

Δh_m is the difference between the mean building height and the mobile antenna height;

x is the horizontal distance between the mobile and the diffracting edges.

When $\Delta h_m = 10.5\text{m}$, $x = 15\text{m}$, and $b = 80\text{m}$, as typical in an urban and suburban environment with average buildings of four story height, the above path loss expression reduces to a simple function of the transmitter to receiver distance R (in kilometres), the base station antenna height measured from the average rooftop Δh_b (in metres), and frequency f (in MHz),

$$L = [40(1-4 \times 10^{-3} \Delta h_b)] \log_{10}(R) - 18 \log_{10}(\Delta h_b) + 21 \log_{10}(f) + 80 \text{ dB}$$

NOTE 1: L shall in no circumstances be less than free space loss.

NOTE 2: The path loss model is valid for a range of Δh_b from 0 to 50 metres.

B.1.8.2 Channel Impulse Response Model

The channel model to be used for simulation is a discrete wide sense stationary uncorrelated scattering (WSSUS) channel model for which the received signal is represented by the sum of delayed replicas of the input signal weighted by independent zero-mean complex Gaussian time variant processes. Specifically, if $z(t)$, $w(t)$ denote the complex low pass representations of the channel input and output, respectively, then

$$w(t) = \sum_{n=1}^N \sqrt{p_n} g_n(t) z(t - \tau_n)$$

⁹

Xia, H.H. et al, "Microcellular Propagation Characteristics for Personal Communications in Urban and Suburban environments," IEEE Transaction on Vehicular Technology, Vol. 43, No. 3, August 1994, pp. 743-752.

where p_n is the strength of the n^{th} weight, and $g_n(t)$ is the complex Gaussian process weighting the n^{th} replica.

The power spectrum of $g_n(t)$, called the Doppler spectrum of the n^{th} path, controls the rate of fading due to the n^{th} path. To completely define this channel model requires only a specification of the Doppler spectra of the tap weights $\{P_n(\nu); n = 1, \dots, N\}$, the tap delays $\{\tau_n; n=1, \dots, N\}$, and the tap weight strengths $\{p_n; n = 1, \dots, N\}$.

The process $g_n(t)$ is to be interpreted as modelling the superposition of unresolved multipath components arriving from different angles and in the vicinity of the delay interval

$$\left(\tau_n - \frac{1}{2W} < \tau < \tau_n + \frac{1}{2W} \right)$$

where W is the bandwidth of the transmitted signal.

Each ray, in general, has a different Doppler shift corresponding to a different value of the cosine of the angle between the ray direction and the velocity vector. In the interests of simplicity the following assumptions are made:

- 1) For outdoor channels a very large number of receive rays arrive uniformly distributed in azimuth at the mobile station and at zero elevation for each delay interval. Also, the antenna pattern is assumed to be uniform in the azimuthal direction. At the base station in general the received rays arrive in a limited range in azimuth.
- 2) For indoor channels a very large number of receive rays arrive uniformly distributed in elevation and azimuth for each delay interval at the base station. Also, the antenna is assumed to be either a short or half-wave vertical dipole.

Assumption 1 is identical to that used by *Clarke*¹⁰ and *Jakes*¹¹ in narrow band channel modelling. Thus the same Doppler spectrum will result, i.e.,

$$P_n(\nu) = P(\nu) = \frac{1}{\pi} \frac{1}{\sqrt{\left(\frac{V}{\lambda}\right)^2 - \nu^2}} \quad ; \quad |\nu| < \frac{V}{\lambda}$$

where V is the velocity of the mobile and λ is the wavelength at the carrier frequency. The term **CLASSIC** is used to identify this Doppler spectrum.

Assumption 2 results in a Doppler spectrum that is nearly flat, and the choice of a flat spectrum has been made, i.e.,

$$P_n(\nu) = P(\nu) = \frac{\lambda}{2V} \quad ; \quad |\nu| < \frac{V}{\lambda}$$

Hence, this Doppler spectrum is referred to as "**FLAT**".

¹⁰ Clark, R.H., "A Statistical Theory of Mobile Reception," BSJT, Vol. 49, 1968, pp 957-1000.

¹¹ Jakes, W.C. (Editor), Microwave Mobile Communications, John Wiley & Sons, 1974.

Annex C: Detailed Evaluation Procedures

This is same as in REVAL.

C.1 Introduction

This annex lists technical attributes which should be considered for the evaluation of RTTs against each of the criteria and gives indication on what possible impact they may have upon the different criteria. Other information submitted based on the template in Annex A, or additionally relevant information, may be considered during the evaluation. The evaluation described in this annex shall be done on the basis of the deployment models in Annex B. RTT performance evaluation is to be based on a common set of verifiable parameter assumptions for all evaluation criteria for each test environment; if conditions change the technology descriptions should explain it. This annex identifies which attributes can be described qualitatively (q) and quantitatively (Q).

When more than one candidate SRTT is evaluated, it is useful to provide summary evaluations for each evaluation criteria. A summary criteria evaluation may be difficult to make when both qualitative and quantitative attributes must be considered and when each technical attribute may have different relative importance with the overall evaluation criteria.

To facilitate such summary criteria evaluations, this annex identifies the importance or relative ranking of the various technical attributes within each evaluation criteria by giving a grouping G1 (most important), G2, G3, G4 (least important). Ranking of some attributes may be different for different test environments, in particular for the satellite environment. These rankings are based upon current anticipated market needs within some countries. It is recognized that the market needs may differ in the various countries in which UMTS may be deployed and that they may also change during the time in which SRTTs are being evaluated. It is also recognized that some new technical attributes or important considerations may be identified during the evaluation procedure that should impact any summary criteria evaluation. As such, evaluation groups may, if appropriate, modify the groupings of technical attributes, or add new attributes or considerations, in determining a summary criteria evaluation. Therefore, all evaluation groups are requested to include in their evaluation reports, information of the summary criteria evaluation including the relative importance which was placed on each technical attribute and any other considerations that affected the summary criteria evaluation.

The evaluation methodology is discussed in section 9.

Index	Criteria and attributes	Q or q	Gn	Related attributes in Annex A
C3.1	<p>Spectrum Efficiency</p> <p>The following entries are considered in the evaluation of spectrum efficiency:</p>			
C3.1.1	For Terrestrial Environment			
C3.1.1.1	<p>Voice traffic capacity (Erlangs/MHz/cell in a total available assigned non-contiguous bandwidth of 30 MHz, 15 MHz forward/15 MHz reverse) for FDD mode or contiguous bandwidth of 30 MHz for TDD mode.</p> <p>This metric must be used for a common generic continuous voice bearer with characteristics 8 kbit/s data rate and an average BER 10^{-3} as well as any other voice bearer included in the proposal which meets the quality requirements (assuming 50% VAD if it is used). For comparison purposes, all measures should assume the use of the deployment models in Annex B, including a 1% call blocking. The descriptions should be consistent with the descriptions under Criterion 6.1.7 - Coverage/Power Efficiency. Any other assumptions and the background for the calculation should be provided, including details of any optional speech CODECs being considered.</p>	<p>Q & q</p> <p>(Q & q) Q</p> <p>(Q & q)</p> <p>(Q & q)</p>	G1	A1.3.1.5.1
C3.1.1.2	<p>Information capacity (Mbps/MHz/cell in a total available assigned non-contiguous bandwidth of 30 MHz, 15 MHz forward/15 MHz reverse) for FDD mode or contiguous bandwidth of 30 MHz for TDD mode.</p> <p>The information capacity is to be calculated for each test service or traffic mix for the appropriate test environments. This is the only measure that would be used in the case of multimedia, or for classes of services using multiple speech coding bit rates. Information capacity is the instantaneous aggregate user bit rate of all active users over all channels within the system on a per cell basis. If the user traffic (voice and/or data) is asymmetric and the system can take advantage of this characteristic to increase capacity, it should be described qualitatively for the purposes of evaluation.</p>	<p>Q & q</p> <p>(Q & q) Q</p> <p>(Q & q)</p> <p>(Q & q)</p>	G1	A1.3.1.5.2

C3.1.2	<p>For Satellite Environment</p> <p>These values (A3.1.2.1 & A3.1.2.2) assume the use of the simulation conditions in Annex B. The first definition is valuable for comparing systems with identical user channel rates. The second definition is valuable for comparing systems with different voice and data channel rates.</p>			
C3.1.2.1	<p>Voice information capacity per required RF bandwidth (bits/sec/Hz)</p>	<p>Q (Q & q) Q (Q & q) (Q & q)</p>	G1	A1.3.2.3.1
C3.1.2.2	<p>Voice plus data information capacity per required RF bandwidth (bits/sec/Hz)</p>	<p>Q (Q & q) Q (Q & q) (Q & q)</p>	G1	A1.3.2.3.2
C3.2	<p>Technology Complexity - Effect on Cost of Installation and Operation</p> <p>The considerations under Criterion 6.1.2 - Technology Complexity apply only to the infrastructure, including BSs (the handportable performance is considered elsewhere).</p>			
C3.2.1	<p>Need for echo control</p> <p>The need for echo control is affected by the round trip delay, which is calculated as shown in Figure 1.</p> <p>Referring to Figure 1, consider the round trip delay with the VOCODER (D1, msec) and also without that contributed by the VOCODER (D2, msec).</p> <p>Note: The delay of the CODEC should be that specified by ITU-T for the common generic voice bearer and if there are any proposals for optional CODECs include the information about those also.</p>	Q	G4	<p>A1.3.7.2 A1.3.7.3</p>
C3.2.2	<p>Transmitter Power and System Linearity Requirements</p> <p>Note: Satellite e.i.r.p. is not suitable for evaluation and comparison of SRTTs because it depends very much on satellite orbit.</p> <p>The SRTT attributes in section A3.2.2 impact system cost and complexity, with the resultant desirable effects of improving overall performance in other evaluation criteria. They are as follows.</p>			

C3.2.2.1	Peak Transmitter/Carrier (P_b) Power (not applicable to satellite) Peak transmitter power for the BS should be considered because lower peak power contributes to lower cost. Note that P_b may vary with test environment application. This is the same peak transmitter power assumed in Annex B, Link budget template (Table 1.3).	Q	G1	A1.2.16.2.1
C3.2.2.2	Broadband Power Amplifier (PA) (not applicable to satellite) Is a broadband power amplifier used or required? If so, what are the peak and average transmitted power requirements into the antenna as measured in watts.	Q	G1	A1.4.10 A1.2.16.2.1 A1.2.16.2.2 A1.5.5 A1.2.5
C3.2.2.3	Linear Base Transmitter and Broadband Amplifier Requirements (not applicable to satellite)			
C3.2.2.3.1	Adjacent channel splatter/emission and intermodulation affect system capacity and performance. Describe these requirements and the linearity and filtering of the base transmitter and broadband PA required to achieve them.	q	G3	A1.4.2 A1.4.10
C3.2.2.3.2	Also state the base transmitter and broadband PA (if one is used) peak to average transmitter output power, as a higher ratio requires greater linearity, heat dissipation and cost.	Q & q	G2	A1.4.10 A1.2.16.2.1 A1.2.16.2.2
C3.2.2.4	Receiver Linearity Requirements (not applicable to satellite) Is BS receiver linearity required? If so, state the receiver dynamic range required and the impact of signal input variation exceeding this range, e.g., loss of sensitivity and blocking.	q	G4	A1.4.11 A1.4.12
C3.2.3	Power Control Characteristics (not applicable to satellite) Does the proposed SRTT utilize transmitter power control? If so, is it used in both forward and reverse links? State the power control range, step size in dB and required accuracy, number of possible step sizes and number of power controls per second, which are concerned with BS technology complexity.	Q & q	G4	A1.2.22 A1.2.22.1 A1.2.22.2 A1.2.22.3 A1.2.22.4 A1.2.22.5
C3.2.4	Transmitter/Receiver Isolation Requirement (not applicable to satellite) If FDD is used, specify the noted requirement and how it is achieved.	q	G3	A1.2.2 A1.2.2.2 A1.2.2.1

C3.2.5	Digital Signal Processing Requirements			
C3.2.5.1	<p>Digital signal processing can be a significant proportion of the hardware for some radio interface proposals. It can contribute to the cost, size, weight and power consumption of the BS and influence secondary factors such as heat management and reliability. Any digital circuitry associated with the network interfaces should not be included. However any special requirements for interfacing with these functions should be included.</p> <p>This section of the evaluation should analyse the detailed description of the digital signal processing requirements, including performance characteristics, architecture and algorithms, in order to estimate the impact on complexity of the BSs. At a minimum the evaluation should review the signal processing estimates (MOPS, memory requirements, gate counts) required for demodulation, equalization, channel coding, error correction, diversity processing (including Rake receivers), adaptive antenna array processing, modulation, A-D and D-A converters and multiplexing as well as some IF and baseband filtering. For new technologies, there may be additional or alternative requirements (such as FFTs).</p> <p>Although specific implementations are likely to vary, good sample descriptions should allow the relative cost, complexity and power consumption to be compared for the candidate SRTTs, as well as the size and the weight of the circuitry. The descriptions should allow the evaluators to verify the signal processing requirement metrics, such as MOPS, memory and gate count, provided by the SRTT proponent.</p>	Q & q	G2	A1.4.13
C3.2.5.2	What is the channel coding/error handling for both the forward and reverse links. Provide details and ensure that implementation specifics are described and their impact considered in DSP requirements described in section A3.2.5.1.	q	G4	A1.2.12 A1.4.13
C3.2.6	<p>Antenna Systems</p> <p>The implementation of specialized antenna systems while potentially increasing the complexity and cost of the overall system can improve spectrum efficiency (e.g. smart antennas), quality (e.g. diversity), and reduce system deployment costs (e.g. remote antennas, leaky feeder antennas).</p> <p>Note: For the satellite component, diversity indicates the number of satellites involved; the other antenna attributes do not apply.</p>			
C3.2.6.1	Diversity: Describe the diversity schemes applied (including micro and macro diversity schemes). Include in this description the degree of improvement expected, and the number of additional antennas and receivers required to implement the proposed diversity design beyond and omni-directional antenna.	Q	G2	A1.2.23 A1.2.23.1 A1.2.23.2
C3.2.6.2	Remote Antennas: Describe whether and how remote antenna systems can be used to extend coverage to low traffic density areas.	q	G2	A1.3.6
C3.2.6.3	Distributed Antennas: Describe whether and how distributed antenna designs are used.	q	G3	A1.3.6
C3.2.6.4	Unique Antenna: Describe additional antenna systems which are either required or optional for the proposed system, e.g., beam shaping, leaky feeder. Include in the description the advantage or application of the antenna system.	q	G4	A1.3.6

C3.2.7	<p>BS Frequency Synchronization/Time Alignment Requirements</p> <p>Does the proposed SRTT require base transmitter and/or receiver station synchronization or base-to-base bit time alignment? If so, specify the long term (1 year) frequency stability requirements, and also the required bit-to-bit time alignment. Describe the means of achieving this.</p>	Q & q	G3	A1.4.1 A1.4.3
C3.2.8	<p>The number of users per RF carrier/frequency channel that the proposed SRTT can support affects overall cost - especially as bearer traffic requirements increase or geographic traffic density varies widely with time.</p> <p>Specify the maximum number of user channels that can be supported while still meeting ITU-T G.726 performance requirements for voice traffic.</p>	Q	G1	A1.2.17
C3.2.9	<p>Base Site Implementation/Installation Requirements (not applicable to satellite)</p> <p>BS size, mounting, antenna type and height can vary greatly as a function of cell size, SRTT design and application environment. Discuss its positive or negative impact on system complexity and cost.</p>	q	G1	A1.4.17
C3.2.10	<p>Handover Complexity</p> <p>Consistent with handover quality objectives defined in Criterion 6.1.3, describe how user handover is implemented for both voice and data services and its overall impact on infrastructure cost and complexity.</p>	Q & q	G1	A1.2.24 A1.4.6.1
C3.3	Quality			
C3.3.1	<p>Transparent Reconnect Procedure for Dropped Calls</p> <p>Dropped calls can result from shadowing and rapid signal loss. Air interfaces utilizing a transparent reconnect procedure - that is, the same as that employed for hand-off - mitigate against dropped calls whereas SRTTs requiring a reconnect procedure significantly different from that used for hand-off do not.</p>	q	G2	A1.4.14
C3.3.2	<p>Round trip delay, D1 (with VOCODER, msec) and D2 (without VOCODER, msec)- See Figure 1.</p> <p>Note: The delay of the CODEC should be that specified by ITU-T for the common generic voice bearer and if there are any proposals for optional CODECs include the information about those also. (For the satellite component, the satellite propagation delay is not included).</p>	Q	G2	A1.3.7.1 A1.3.7.2
C3.3.3	<p>Handover/ALT Quality</p> <p>Intra Switch/Controller handover directly affects voice service quality.</p> <p>Handover performance, minimum break duration, and average number of handovers are key issues.</p>	Q	G2	A1.2.24 A1.2.24.1 A1.2.24.2 A1.4.6.1

C3.3.4	<p>Handover Quality for Data</p> <p>There should be a quantitative evaluation of the effect on data performance of handover.</p>	Q	G3	<p>A1.2.24</p> <p>A1.2.24.1</p> <p>A1.2.24.2</p> <p>A1.4.6.1</p>
C3.3.5	<p>Maximum user bit rate for data (kbps)</p> <p>A higher user bit rate potentially provides higher data service quality (such as high quality video service) from the user's point of view.</p>	Q	G1	A1.3.3
C3.3.6	<p>Channel Aggregation to Achieve Higher User Bit</p> <p>There should also be a qualitative evaluation of the method used to aggregate channels to provide higher bit rate services.</p>	q	G4	A1.2.32
C3.3.7	<p>Voice Quality</p> <p>Recommendation ITU-R M.1079 specifies that UMTS speech quality without errors should be equivalent to ITU-T G.726 (32 kbps ADPCM) with desired performance at ITU-T G.711 (64 kbps PCM).</p> <p>Note : Voice Quality equivalent to ITU-T G.726 error free with no more than a 0.5 degradation in MOS in the presence of 3% frame erasures might be a requirement.</p>	Q & q	G1	<p>A1.2.19</p> <p>A1.3.8</p>
C3.3.8	<p>System Overload Performance (not applicable to satellite)</p> <p>Evaluate the effect on system blocking and quality performance on both the primary and adjacent cells during an overload condition, at e.g. 125%, 150%, 175%, 200%. Also evaluate any other effects of an overload condition.</p>	Q & q	G3	A1.3.9.1
C3.4	Flexibility of Radio Technologies			
C3.4.1	Services aspects			
C3.4.1.1	<p>Variable user bit rate capabilities</p> <p>Variable user bit rate applications can consist of the following:</p> <ul style="list-style-type: none"> - adaptive signal coding as a function of RF signal quality - adaptive voice coder rate as a function of traffic loading as long as ITU-T G.726 performance is met - variable data rate as a function of user application - variable voice/data channel utilization as a function of traffic mix requirements. <p>Some important aspects which should be investigated are as follows:</p> <ul style="list-style-type: none"> - how is variable bit rate supported? - what are the limitations? <p>Supporting technical information should be provided such as</p> <ul style="list-style-type: none"> - the range of possible data rates - the rate of changes (in ms). 	q & Q	G2	<p>A1.2.18</p> <p>A1.2.18.1</p>

C3.4.1.2	Maximum tolerable Doppler shift, F_d (Hz) for which voice & data quality requirements are met (terrestrial only) Supporting technical information: F_d	q & Q	G3	A1.3.1.4
C3.4.1.3	Doppler Compensation Method (satellite component only) What is the Doppler compensation method and residual Doppler shift after compensation?	Q & q	G3	A1.3.2.2
C3.4.1.4	How the maximum tolerable delay spread of the proposed technology impact the flexibility (e.g., ability to cope with very high mobile speed)?	q	G3	A1.3.1.3 A1.2.14 A1.2.14.1 A1.2.14.2 A1.3.10
C3.4.1.5	Maximum user information bit rate, R_u (kbps) How flexibly services can be offered to customers ? What is the limitation in number of users for each particular service? (e.g. no more than two simultaneous 2 Mbit/s users)	Q & q	G2	A1.3.3 A1.3.1.5.2 A1.2.31 A1.2.32
C3.4.1.6	Multiple VOCODER rate capability - bit rate variability - delay variability - error protection variability	Q & q	G3	A1.2.19 A1.2.19.1 A1.2.7 A1.2.12
C3.4.1.7	Multimedia capabilities The proponents should describe how multimedia services are handled. The following items should be evaluated: - possible limitations (in data rates, number of bearers) - ability to allocate extra bearers during of the communication - constraints for handover.	Q & q	G1	A1.2.21 A1.2.20 A1.3.1.5.2 A1.2.18 A1.2.24 A1.2.30 A1.2.30.1
C3.4.2	Planning			
C3.4.2.1	Spectrum related matters			
C3.4.2.1.1	Flexibility in the use of the frequency band The proponents should provide the necessary information related to this topic (e.g., allocation of sub-carriers with no constraints, handling of asymmetric services, usage of non-paired band).	q	G1	A1.2.1 A1.2.2 A1.2.2.1 A1.2.3 A1.2.5.1

C3.4.2.1.2	<p>Spectrum sharing capabilities</p> <p>The proponent should indicate how global spectrum allocation can be shared between operators in the same region.</p> <p>The following aspects may be detailed:</p> <ul style="list-style-type: none"> - Means for spectrum sharing between operators in the same region - Guardband between operators in case of fixed sharing. 	q & Q	G4	A1.2.26
C3.4.2.1.3	<p>Minimum frequency band necessary to operate the system in good conditions</p> <p>Supporting technical information:</p> <ul style="list-style-type: none"> - impact of the Frequency Reuse pattern - bandwidth necessary to carry high peak data rate. 	Q & q	G1	A1.2.1 A1.4.15 A1.2.5
C3.4.2.2	Radio resource planning			
C3.4.2.2.1	<p>Allocation of radio resources</p> <p>The proponents and evaluators should focus on the requirements and constraints imposed by the proposed technology. More particularly, the following aspects should be considered:</p> <ul style="list-style-type: none"> - What are the methods used to make the allocation and planning of radio resources flexible? - What are the impacts on the network side (e.g. synchronization of BSs, signalling,)? - Other aspects. <p>Examples of functions or type of planning required which may be supported by the proposed technology:</p> <ul style="list-style-type: none"> - DCA - frequency hopping - code planning - time planning - interleaved frequency planning. <p>Note: The use of the second adjacent channel instead of the adjacent channel at a neighbouring cluster cell is called "interleaved frequency planning".</p> <p>In some cases, no particular functions are necessary (e.g. Frequency Reuse = 1).</p>	q	G2	A1.2.25 A1.2.27 A1.4.15

C3.4.2.2.2	<p>Adaptability to adapt to different and/or time varying conditions (e.g., propagation, traffic)</p> <p>How the proposed technology cope with varying propagation and/or traffic conditions?</p> <p>Examples of adaptive functions which may be supported by the proposed technology:</p> <ul style="list-style-type: none"> - DCA - link adaptation - fast power control - adaptation to large delay spreads. <p>Some adaptivity aspects may be inherent to the SRTT.</p>	q	G2	<p>A1.3.10</p> <p>A1.2.27</p> <p>A1.2.22</p> <p>A1.2.14</p>
C3.4.2.3	Mixed Cell Architecture (not applicable to satellite component)			
C3.4.2.3.1	<p>Frequency management between different layers</p> <p>What kind of planning is required to manage frequencies between the different layers? e.g.</p> <ul style="list-style-type: none"> - fixed separation - dynamic separation. - possibility to use the same frequencies between different layers. <p>Possible supporting technical information:</p> <ul style="list-style-type: none"> - guard band. 	q & Q	G1	<p>A1.2.28</p> <p>A1.4.15</p>
C3.4.2.3.2	<p>User adaptation to the environment</p> <p>What are the constraints to the management of users between the different cell layers? e.g.</p> <ul style="list-style-type: none"> - constraints for handover between different layers - adaptation to the cell layers depending on services, mobile speed, mobile power. 	q	G2	<p>A1.2.28</p> <p>A1.3.10</p>
C3.4.2.4	Fixed-Wireless Access			
C3.4.2.4.1	<p>The proponents should indicate how well its technology is suited for operation in the Fixed Wireless Access environment.</p> <p>Areas which would need evaluation include (not applicable to satellite component):</p> <ul style="list-style-type: none"> - Ability to deploy small BSs easily - Use of repeaters - Use of large cells - Ability to support fixed and mobile users within a cell - Network and signalling simplification. 	q	G4	<p>A1.1.3</p> <p>A1.3.5</p> <p>A1.4.17</p> <p>A1.4.7</p> <p>A1.4.7.1</p>

C3.4.2.4.2	Possible use of adaptive antennas (how well suited is the technology) (not applicable to satellite component) Is SRTT suited to introduce adaptive antennas? Explain the reason if it is.	q	G4	A1.3.6
C3.4.2.4.3	Existing system migration capability and backwards compatibility to GSM/DCS	q	G1	A1.4.16 A.1.4.33
C3.5	Implication on Network Interface			
C3.5.1	Examine the synchronization requirements with respect to the network interfaces. Best case: No special accommodation necessary to provide synchronization. Worst case: Special accommodation for synchronization is required, e.g. additional equipment at BS or special consideration for facilities.	q	G4	A1.4.3
C3.5.2	Examine the SRTTs ability to minimize the network infrastructure involvement in cell handover. Best case: Neither PSTN/ISDN nor mobile switch involvement in handover. Worst case: Landline network involvement essential for handover.	q	G3	A1.2.24 A1.4.6.1
C3.5.3	Landline Feature Transparency			
C3.5.3.1	Examine the network modifications required for the SRTT to pass the standard set of ISDN bearer services. Best case: No modifications required. Worst case: Substantial modification required, such as interworking functions.	q	G1	A1.4.7.1
C3.5.3.2	Examine the extent of the PSTN/ISDN involvement in switching functionality. Best case: All switching of calls is handled by the PSTN/ISDN. Worst case: A separate mobile switch is required.	q	G2	A1.4.6 A1.4.8
C3.5.3.3	Examine the depth and duration of fading that would result in a dropped call to the PSTN/ISDN network. The robustness of an SRTTs ability to minimize dropped calls could be provided by techniques such as transparent reconnect.	Q & q	G3	A1.2.24 A1.4.14
C3.5.3.4	Examine the quantity and type of network interfaces necessary for the SRTT based on the deployment model used for spectrum and coverage efficiencies. The assessment should include those connections necessary for traffic, signalling and control as well as any special requirements, such as soft handover or simulcast.	Q	G2	A1.2.30 A1.2.30.1 A1.4.9
C3.6	Handportable Performance Optimization Capability			
C3.6.1	Isolation between transmitter and receiver Isolation between transmitter and receiver has an impact on the size and weight of the handportable.	Q	G2	A1.2.2 A1.2.2.1 A1.2.2.2

C3.6.2	Average terminal power output P_o (mW) Lower power gives longer battery life and greater operating time.	Q	G2	A1.2.16.1.2
C3.6.3	System Round Trip Delay impacts the amount of acoustical isolation required between handportable microphone and speaker components and, as such, the physical size and mechanical design of the subscriber unit. Note: The delay of the CODEC should be that specified by ITU-T for the common generic voice bearer and if there are any proposals for optional CODECs include the information about those also. (For the satellite component, the satellite propagation delay is not included).	Q & q	G2	A1.3.7 A1.3.7.1 A1.3.7.2 A1.3.7.3
C3.6.4	Peak transmission power	Q	G1	A1.2.16.1.1
C3.6.5	Power control characteristics Does the proposed SRTT utilize transmitter power control? If so, is it used in both forward and reverse links? State the power control range, step size in dB and required accuracy, number of possible step sizes and number of power controls per second, which are concerned with mobile station technology complexity.			
C3.6.5.1	Power control dynamic range Larger power control dynamic range gives longer battery life and greater operating time.	Q	G3	A1.2.22 A1.2.22.3 A1.2.22.4
C3.6.5.2	Power control step size, accuracy and speed	Q	G3	A1.2.22 A1.2.22.1 A1.2.22.2 A1.2.22.5
C3.6.6	Linear transmitter requirements	q	G3	A1.4.10
C3.6.7	Linear receiver requirements (not applicable to satellite)	q	G3	A1.4.11
C3.6.8	Dynamic range of receiver The lower the dynamic range requirement, the lower the complexity and ease of design implementation.	Q	G3	A1.4.12
C3.6.9	Diversity schemes Diversity has an impact on handportable complexity and size. If utilized describe the type of diversity and address the following two attributes.	Q & q	G1	A1.2.23 A1.2.23.1 A1.2.23.2
C3.6.10	The number of antennas	Q	G1	A1.2.23.1
C3.6.11	The number of receivers	Q	G1	A1.2.23.1
C3.6.12	Frequency Stability Tight frequency stability requirements contribute to handportable complexity.	Q	G3	A1.4.1.2

C3.6.13	The ratio of "off (sleep)" time to "on" time	Q	G1	A1.2.29 A1.2.29.1
C3.6.14	Frequency generator step size, switched speed and frequency range Tight step size, switch speed and wide frequency range contribute to handportable complexity. Conversely, they increase SRTT flexibility.	Q	G2	A1.4.5
C3.6.15	Digital signal processing requirements Digital signal processing can be a significant proportion of the hardware for some radio interface proposals. It can contribute to the cost, size, weight and power consumption of the BS and influence secondary factors such as heat management and reliability. Any digital circuitry associated with the network interfaces should not be included. However any special requirements for interfacing with these functions should be included. This section of the evaluation should analyse the detailed description of the digital signal processing requirements, including performance characteristics, architecture and algorithms, in order to estimate the impact on complexity of the BSs. At a minimum the evaluation should review the signal processing estimates (MOPS, memory requirements, gate counts) required for demodulation, equalization, channel coding, error correction, diversity processing (including Rake receivers), adaptive antenna array processing, modulation, A-D and D-A converters and multiplexing as well as some IF and baseband filtering. For new technologies, there may be additional or alternative requirements (such as FFTs). Although specific implementations are likely to vary, good sample descriptions should allow the relative cost, complexity and power consumption to be compared for the candidate SRTTs, as well as the size and the weight of the circuitry. The descriptions should allow the evaluators to verify the signal processing requirement metrics, such as MOPS, memory and gate count, provided by the SRTT proponent.	Q & q	G1	A1.4.13
C3.7	Coverage/Power Efficiency			
C3.7.1	Terrestrial Coverage Efficiency: - The coverage efficiency is considered for the lowest traffic loadings. - The base site coverage efficiency can be quantitatively determined by addressing coverage limitation and/or by calculating the maximum coverage range for the lowest traffic loading.			

C3.7.1.1	<p>Base site coverage efficiency</p> <p>The number of base sites required to provide coverage at system start-up and ongoing traffic growth significantly impacts cost. From section 1.3.2 of Annex B, determine the coverage efficiency, C (km²/base sites), for the lowest traffic loadings. Proponent has to indicate the background of the calculation and also to indicate the maximum coverage range.</p>	Q	G1	<p>A1.3.1.7</p> <p>A1.3.1.7.1</p> <p>A1.3.1.7.2</p> <p>A1.3.4</p>
C3.7.1.2	<p>Method to increase the coverage efficiency</p> <p>Proponent describes the technique adopted to increase the coverage efficiency and drawbacks.</p> <p>Remote antenna systems can be used to economically extend vehicular coverage to low traffic density areas. SRTT link budget, propagation delay system noise and diversity strategies can be impacted by their use.</p> <p>Distributed antenna designs - similar to remote antenna systems - interconnect multiple antennas to a single radio port via broadband lines. However, their application is not necessary limited to providing coverage, but can also be used to economically provide continuous building coverage for pedestrian applications. System synchronization, delay spread, and noise performance can be impacted by their use.</p>	q	G1	<p>A1.3.5</p> <p>A1.3.6</p>
C3.7.2	<p>Satellite</p> <p>Normalized Power Efficiency</p> <p>Supported information bit rate per required carrier power-to-noise density ratio for the given channel performance under the given interference conditions for voice</p> <p>Supported information bit rate per required carrier power-to-noise density ratio for the given channel performance under the given interference conditions for voice plus data mixed traffic.</p>	Q	G1	<p>A1.3.2.4</p> <p>A1.3.2.4.1</p> <p>A1.3.2.4.2</p>

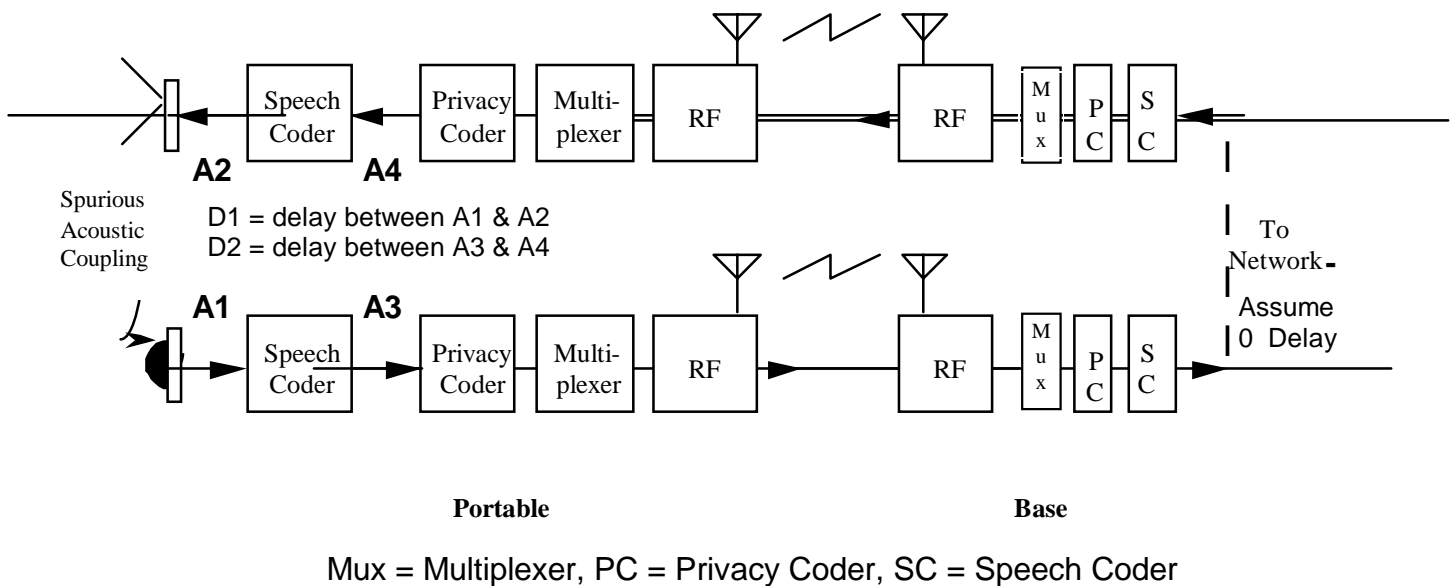

Figure 1

Annex D: Guidance on Simulations

D.1 Introduction

This annex lists information which is intended to clarify the interpretation of evaluation requirements.

D.2 TDD working assumptions

D.2.1 Circuit Switched Data Services

For circuit switched services with 100% activity factors (i.e. constrained delay data), we assume that the traffic is in one direction only. We assume that:

- with probability $\frac{1}{2}$, traffic (with 100% activity) is from the mobile to the base station;
- with probability $\frac{1}{2}$, traffic (with 100% activity) is from the base station to the mobile.

D.2.2 Spectrum efficiency

A satisfied user for a circuit switched service is as follows;

- 1) The user is not blocked when arriving to the system.
- 2) *Over both directions of the entire call together*, $BER > BER_Threshold$ for less than $x_1\%$ of the frames.
- 3) The user is not dropped. A call is dropped if, *in either direction of a call*, $BER > BER_Threshold$ in every frame for more than t_{dropp2} seconds.

D.2.3 Coverage Efficiency - Bit Error Rate

The coverage criterion is that, *over both directions of the entire call together*, $BER > BER_Threshold$ for less than 5% of the frames.

D.3 Finite Area Simulations

Where an infinite area simulation is approximated by a finite area the method used and the measures taken to avoid border effects must be stated

D.4 Decorrelation of Long Term fading - correct interpretation.

Suppose that the lognormal component of the path loss at position P_1 has been determined to be L_1 ; suppose that we wish to compute the lognormal component L_2 at the "next" position P_2 , where P_2 is a distance Δx metres away from P_1 . Then L_2 is normally distributed with mean $R(\Delta x)L_1$ and variance $(1 - R(\Delta x)^2)\sigma^2$, where σ is the standard deviation of the lognormal fading for that environment.

This interpretation is based on the assumption that the successive path loss components L_1 and L_2 are jointly normally distributed, each with zero mean and with correlation $R(\Delta x)$; the distribution quoted for L_2 is then the conditional distribution of L_2 given the value of L_1 .

Annex E: Document change history

SMG	SPEC	CR	PHASE	VER	NEW_VR	SUBJECT
s23	30.03	A001	1	3.0.0	3.1.0	Proposal for changes of ETR 04.02, Annex 2, to remove inconsistencies and to add missing parts to the models
s23	30.03	A002	1	3.0.0	3.1.0	Proposal for changes of ETR 04.02, Annex 2. Spectrum efficiency evaluation and required test cases.
s25	30.03	A004	UMTS	3.1.0	3.2.0	Modification of cell sizes in the Vehicular environment for high bit rate services
s25	30.03	A006	UMTS	3.1.0	3.2.0	Methodology for the evaluation of guard bands between operators

History

Document history		
V3.1.0	November 1997	Publication
V3.2.0	April 1998	Publication