

MC542

Organização de Computadores
Teoria e Prática

2007 - 2011
Prof. Paulo Cesar Centoducatte
ducatte@ic.unicamp.br
www.ic.unicamp.br/~ducatte

MC542
4.1

MC542

Circuitos Lógicos

Projeto de Circuitos Seqüenciais

"DDCA" - (Capítulo 3)
"FDL" - (Capítulo 7)

MC542
4.2

Projeto de Circuitos Seqüenciais
Sumário

- Introdução
- Latches e Flip-Flops
- Projeto de Circuitos Síncronos
- Registradores
 - Uso de Registradores com Barramento
- Registradores de Deslocamento
- Contadores
 - Assíncronos
 - Síncronos

MC542
4.3

Introdução

- As saídas de um circuito seqüencial dependem dos valores presente e passados de suas entradas.
- Lógica seqüencial possui memória.
- Algumas definições:
 - Estado (State): conjunto de informações a cerca do circuito necessárias para se prever o seu comportamento futuro.
 - Latches e flip-flops: elementos de estado que armazenam um bit
 - Circuitos seqüenciais Síncronos: circuito combinacional seguido de um banco de flip-flops

MC542
4.4

Elementos de Estados

- O estado de um circuito determina o seu comportamento futuro
- Elementos de Estado armazenam o estado
 - Circuito bi-estável
 - Latch SR
 - Latch D
 - Flip-flop D
 - » Outros tipos de flip-flops
 - JK
 - T
 - SR

MC542
4.5

Circuito Bi-estável

- Bloco Fundamental para a construção dos outros elementos de estado
- Duas saídas: Q , \bar{Q}
- Sem entradas.

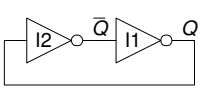
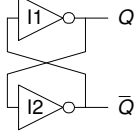



MC542
4.6

Circuito Bi-estável: Comportamento

• Considere os dois casos abaixo:

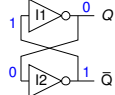
- $Q = 0$: então $\bar{Q} = 1$ e $Q = 0$



- $Q = 1$: então $\bar{Q} = 0$ e $Q = 1$

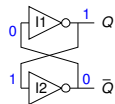

• O circuito bi-estável armazena 1 bit do estado na variável, Q (ou \bar{Q})
 • Porém não há entrada para controle do estado

MC542 4.7

Elemento de Memória com Controle

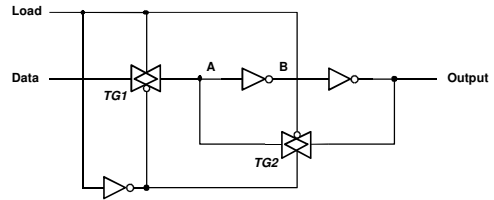

MC542 4.8

SR Latch

• Latch Set/Reset (Latch SR)

• Definições

- Set: Saída igual a 1

- Reset: saída igual a 0

• Quando a entrada set, S , é 1 (e $R = 0$), $Q = 1$

• Quando a entrada reset, R , é 1 (e $S = 0$), $Q = 0$

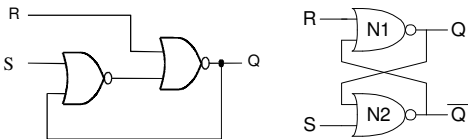

• Qual a tabela verdade?

MC542 4.9

SR Latch

• Considere os quatro casos possíveis:

• $S = 1, R = 0$

• $S = 0, R = 1$

• $S = 0, R = 0$

• $S = 1, R = 1$

MC542 4.10

SR Latch

• $S = 1, R = 0$: then $Q = 1$ and $\bar{Q} = 0$

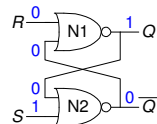

• $S = 0, R = 1$: then $Q = 0$ and $\bar{Q} = 1$

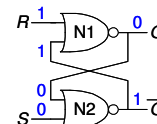

MC542 4.11

SR Latch

• $S = 0, R = 0$: então $Q = Q_{prev}$ e $\bar{Q} = \bar{Q}_{prev}$ (memorial)

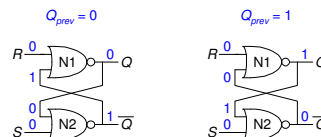

• $S = 1, R = 1$: então $Q = 0$ e $\bar{Q} = 0$ (estado inválido: $\bar{Q} \neq \text{NOT } Q$)

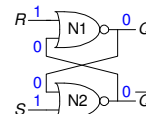

MC542 4.12

SR Latch

S	R	Q _a	Q _b
0	0	0/1	1/0 (no change)
0	1	0	1
1	0	1	0
1	1	0	0

MCS42 4.13

SR Latch

Latch SR

MCS42 4.14

Latch SR com Enable

En	S	R	Q(t+1)
0	x	x	Q(t) (no change)
1	0	0	Q(t) (no change)
1	0	1	0
1	1	0	1
1	1	1	x

MCS42 4.15

Latch SR com Enable

MCS42 4.16

Latch SR com Nand

Qual a tabela verdade?

MCS42 4.17

Latch D

En	D	Q(t+1)
0	x	Q(t)
1	0	0
1	1	1

MCS42 4.18

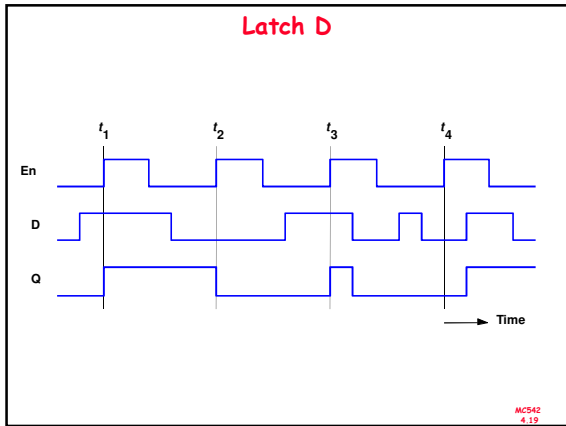

Flip-Flop D

- Duas entradas: *CLK*, *D*
- *Q* só muda na borda (subida ou decida) do *CLK*
- O flip-flop "samples" *D* na borda do *CLK*
- O flip-flop é chamado de dispositivo *edge-triggered* devido a ser ativo na borda do clock

Flip-Flop D

MC542
4.20

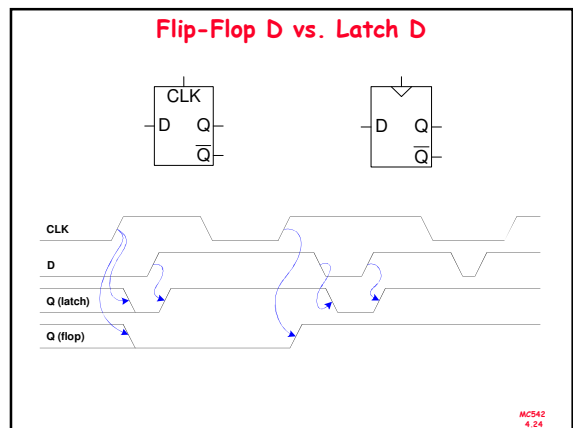
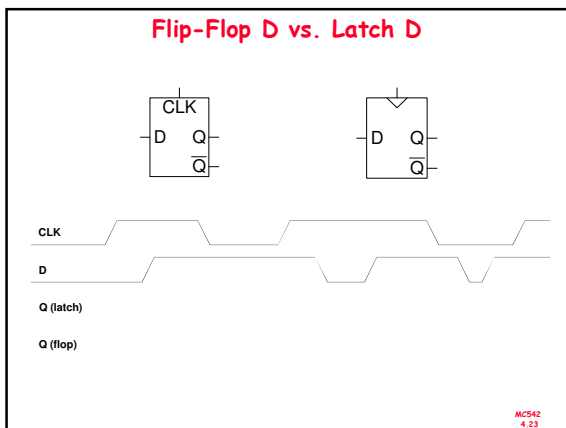
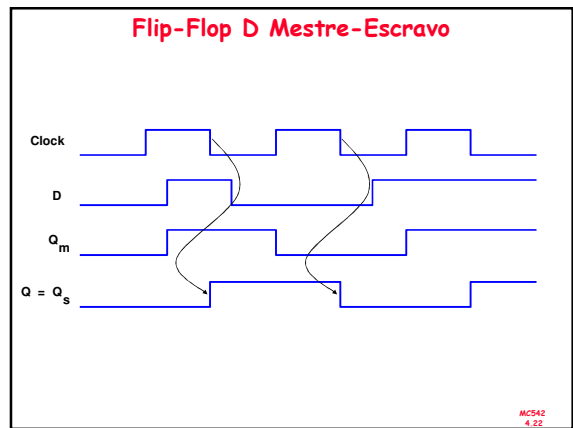
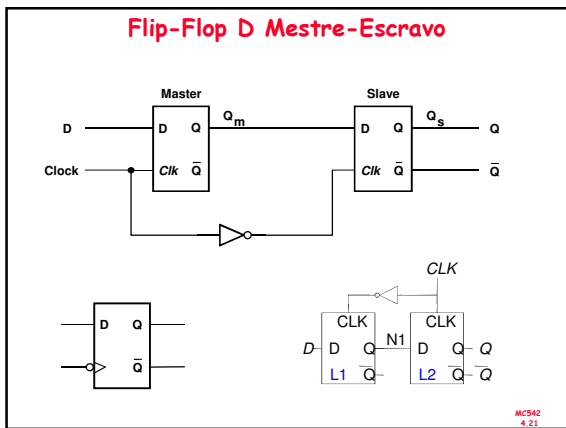

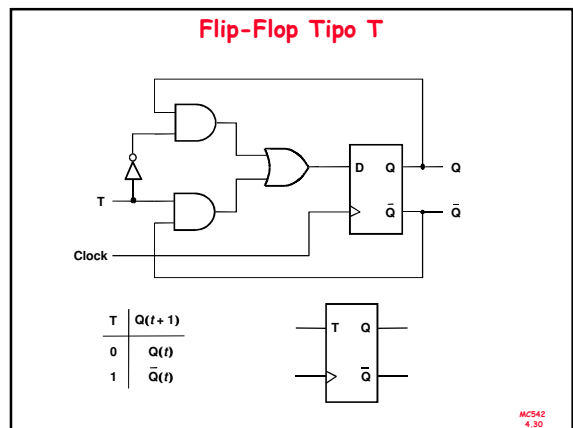
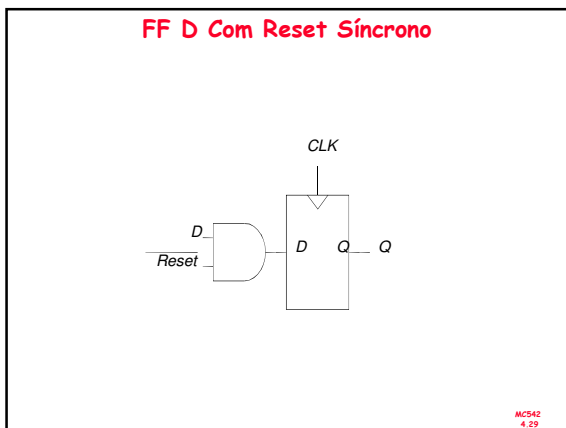
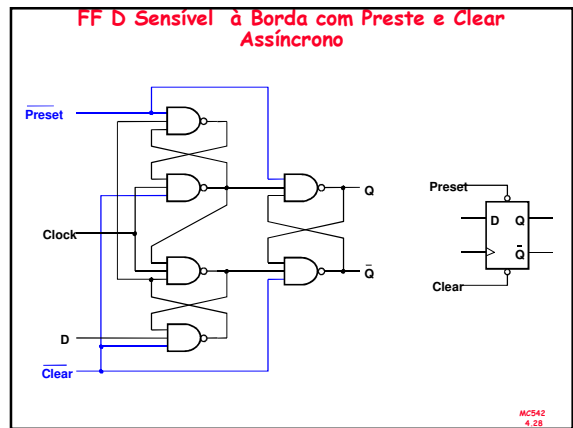
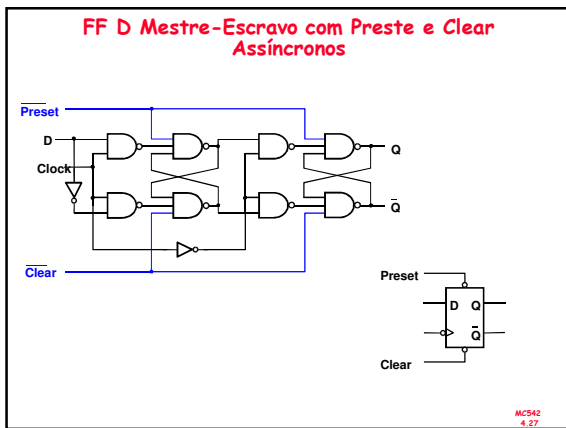
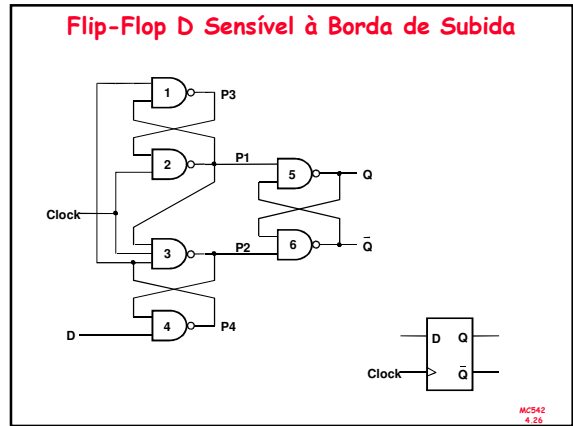
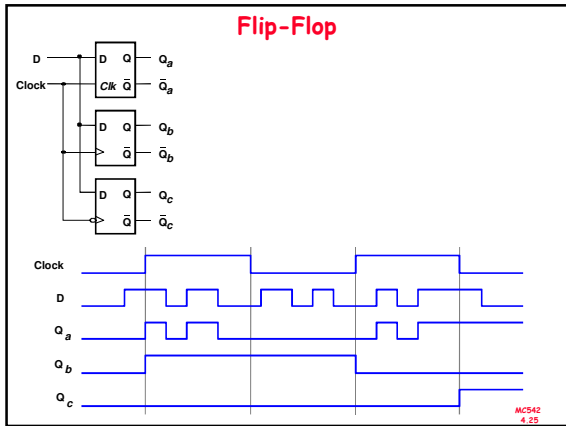

Flip-Flop Tipo JK

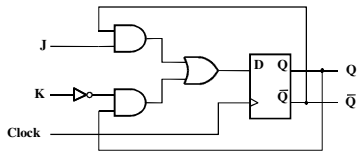

J	K	Q(t+1)
0	0	Q(t)
0	1	0
1	0	1
1	1	$\bar{Q}(t)$



MCS42
4.31

Registradores

- Conjunto de elementos de memória (flip-flops) utilizados para armazenar n bits.
- Utilizam em comum os sinais de clock e controle

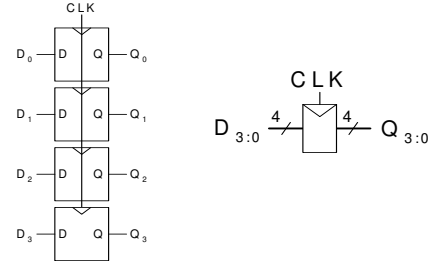

MCS42
4.32

Shift Register

Apresenta o seguinte comportamento:

	In	Q ₁	Q ₂	Q ₃	Q ₄ = Out
t ₀	1	0	0	0	0
t ₁	0	1	0	0	0
t ₂	1	0	1	0	0
t ₃	1	1	0	1	0
t ₄	1	1	1	0	1
t ₅	0	1	1	1	0
t ₆	0	0	1	1	1
t ₇	0	0	0	1	1

MCS42
4.33

Shift Register

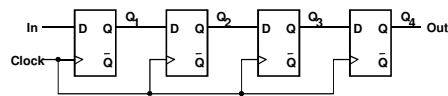

MCS42
4.34

Shift Register com Carga Paralela

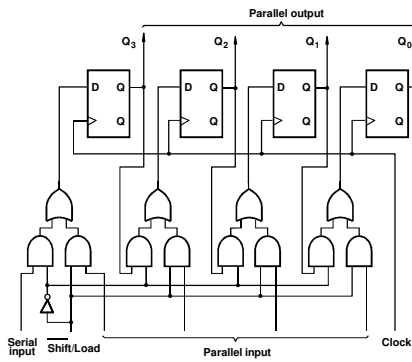

MCS42
4.35

Shift Register Universal

- Entrada Serial
 - Deslocamento a Esquerda
 - Deslocamento a Direita
- Carga Paralela
- Saída Paralela

• Exercício: Desenhe o Diagrama do Shift Register Universal de 4 bits.

MCS42
4.36

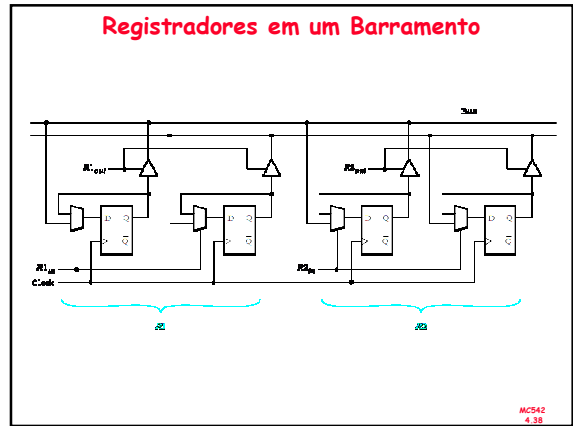
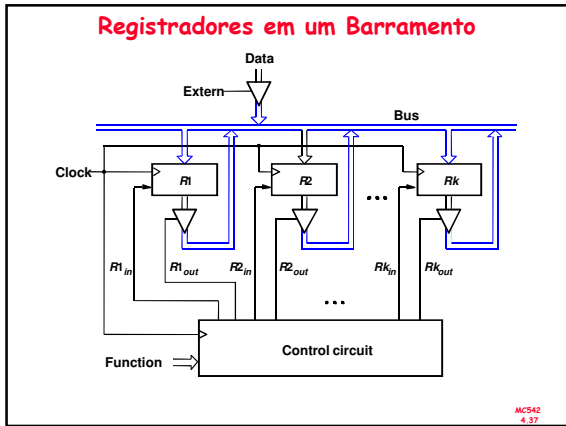

- ### Contadores
- Assíncronos
 - Síncronos
- MCS42
4.39

Contadores

Contador Binário

	clk	Q ₂	Q ₁	Q ₀
t ₀	↑	0	0	0
t ₁	↑	0	0	1
t ₂	↑	0	1	0
t ₃	↑	0	1	1
t ₄	↑	1	0	0
t ₅	↑	1	0	1
t ₆	↑	1	1	0
t ₇	↑	1	1	1

MCS42
4.40

