

# Conditions of Fukushima Dai-ichi Nuclear Power Stations **Unit 1**

## (As of 12:00 March 19th, 2011)

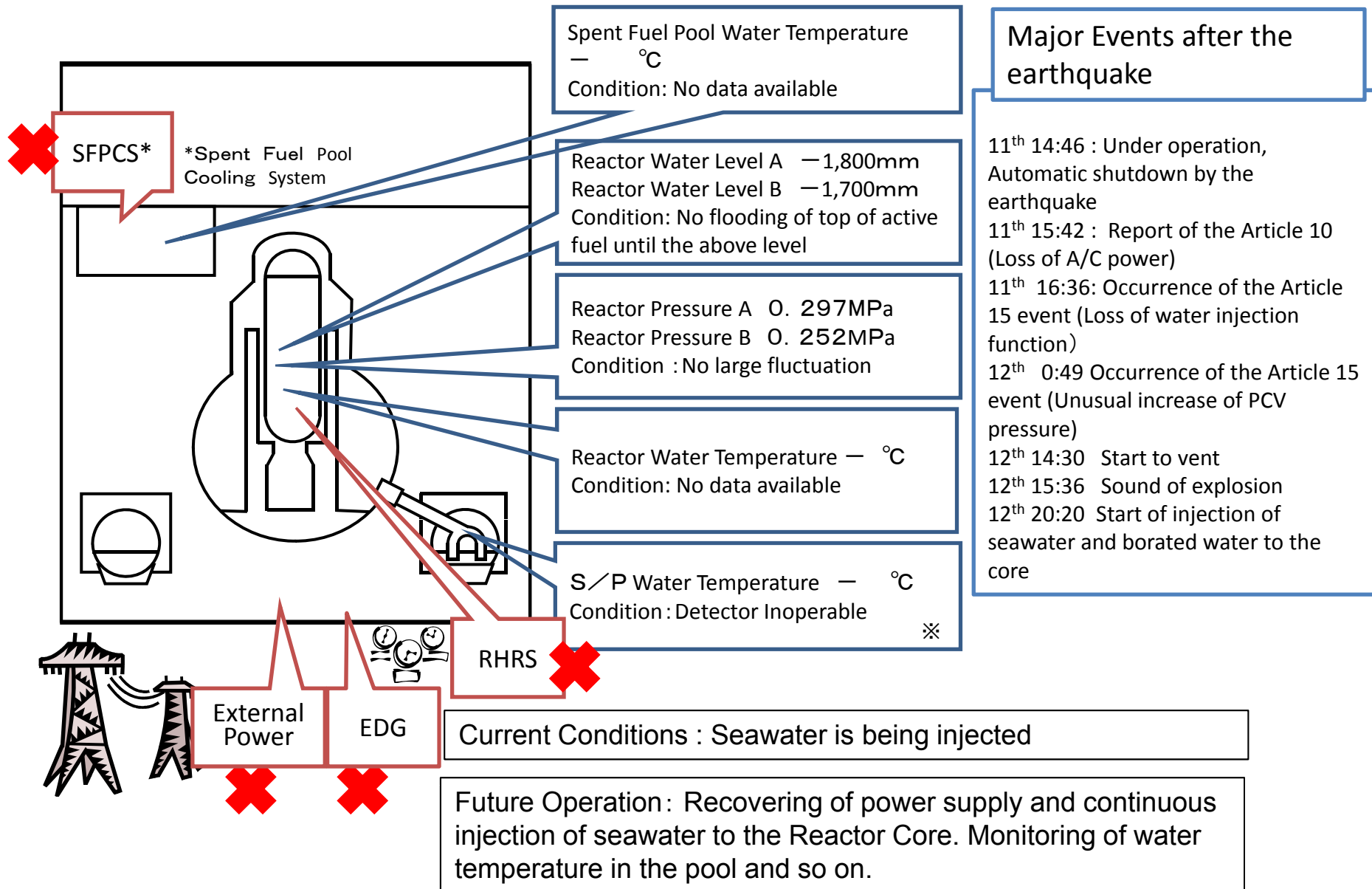

# Conditions of Fukushima Dai-ichi Nuclear Power Stations **Unit 2**

(As of 12:00 March 19th, 2011)

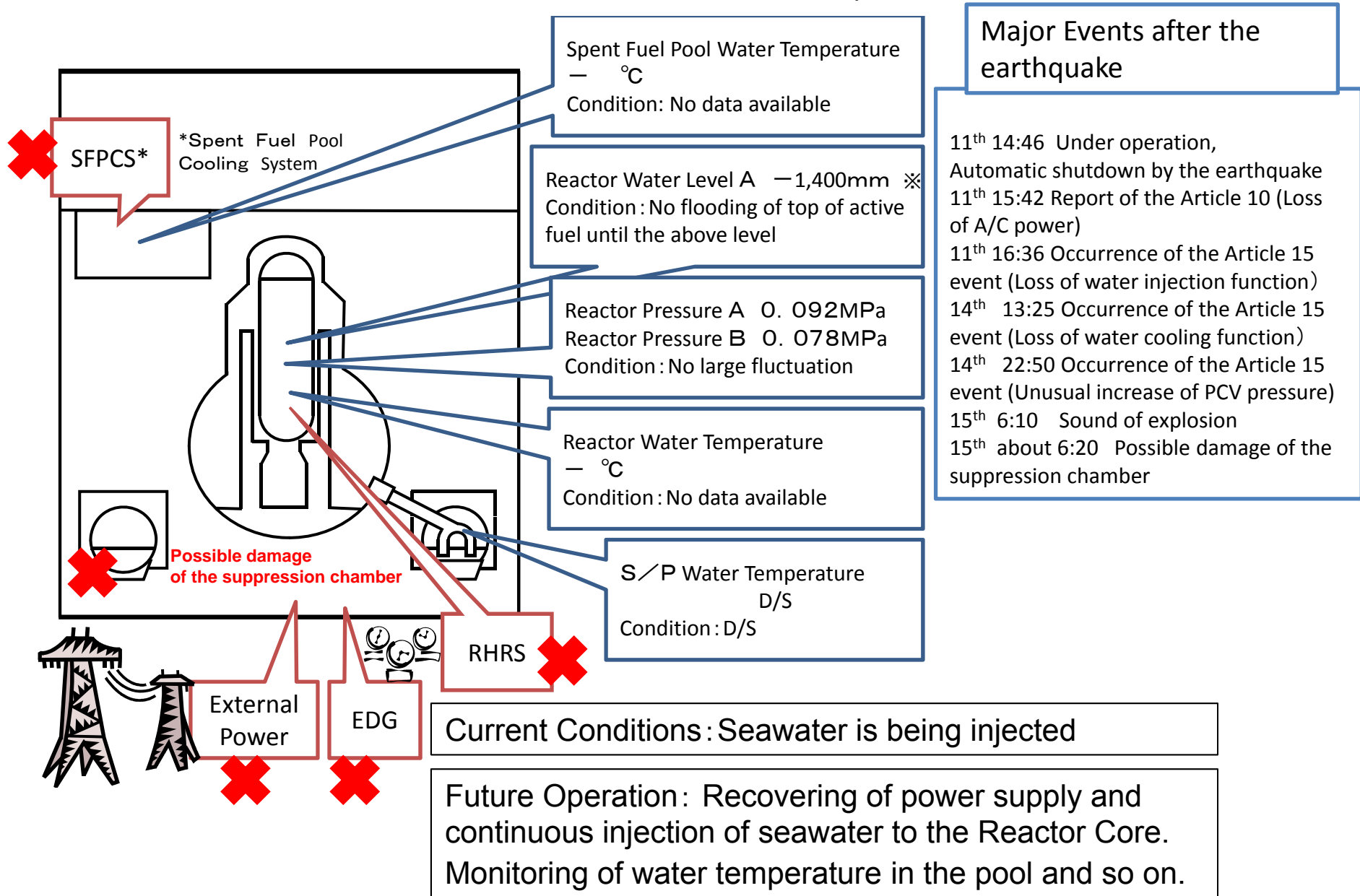

# Conditions of Fukushima Dai-ichi Nuclear Power Stations **Unit 3**

(As of 12:00 March 19th, 2011)

## Major Events after the earthquake

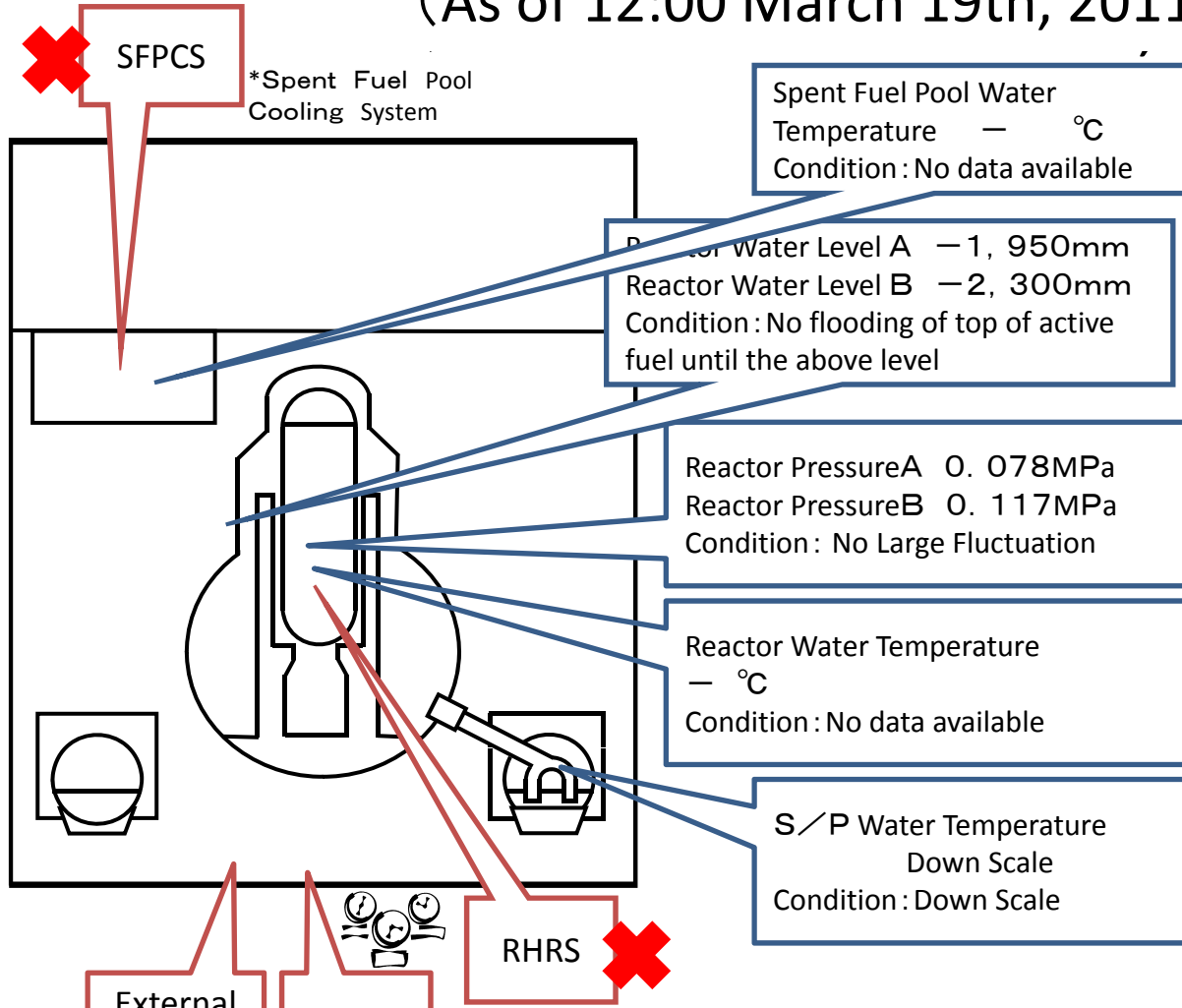

Spent Fuel Pool Water  
Temperature — °C  
Condition : No data available

Reactor Water Level A — 1, 950mm  
Reactor Water Level B — 2, 300mm  
Condition : No flooding of top of active fuel until the above level

Reactor Pressure A 0. 078MPa  
Reactor Pressure B 0. 117MPa  
Condition : No Large Fluctuation

Reactor Water Temperature  
— °C  
Condition : No data available

S / P Water Temperature  
Down Scale  
Condition : Down Scale

- 11<sup>th</sup> 14:46 Under operation, Automatic shutdown by the earthquake
- 11<sup>th</sup> 15:42 Report of the Article 10 (Loss of A/C power)
- 13<sup>th</sup> 5:10 Occurrence of the Article 15 event (Loss of water injection function)
- 13<sup>th</sup> 8:10 Start to vent
- 14<sup>th</sup> 7:44 Occurrence of the Article 15 event (Unusual increase of PCV pressure)
- 11:01 Sound of explosion
- 16<sup>th</sup> about 8:30 White smoke generated
- 17<sup>th</sup> 9:48~10:01 Water discharge by the helicopters of Self-Defense Force (4 times)
- 19:05~20:07 Water spray from the ground by High pressure water-cannon trucks (Police: once, Self-Defense Force: 5 times)
- 18<sup>th</sup> before 14:00~14:38 Water spray from the ground by fire engines (Self-Defense Force: 6 times)
- ~14:45 Water spray from the ground by A fire engine (US armed forces: 1 time)
- 19<sup>th</sup> 0:00~01:00 Hyper Rescue Unit of Tokyo Fire Department carried out water spray

Current Conditions: Continuous operations for water spray to the pool and seawater injection to the Reactor Core

Future Operation: Recovering of power supply and continuous injection of seawater to the Reactor Core.

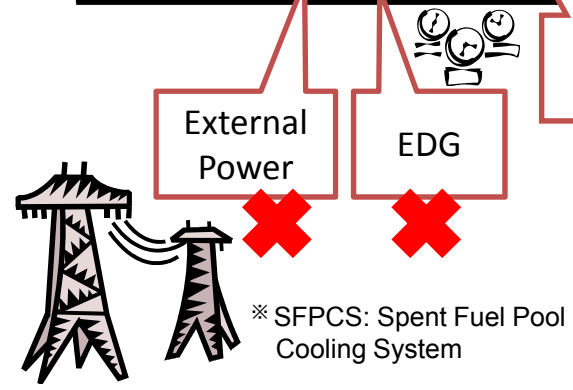

External Power

EDG

RHRS

# Conditions of Fukushima Dai-ichi Nuclear Power Stations Unit 4 (As of 12:00 March 19th, 2011)

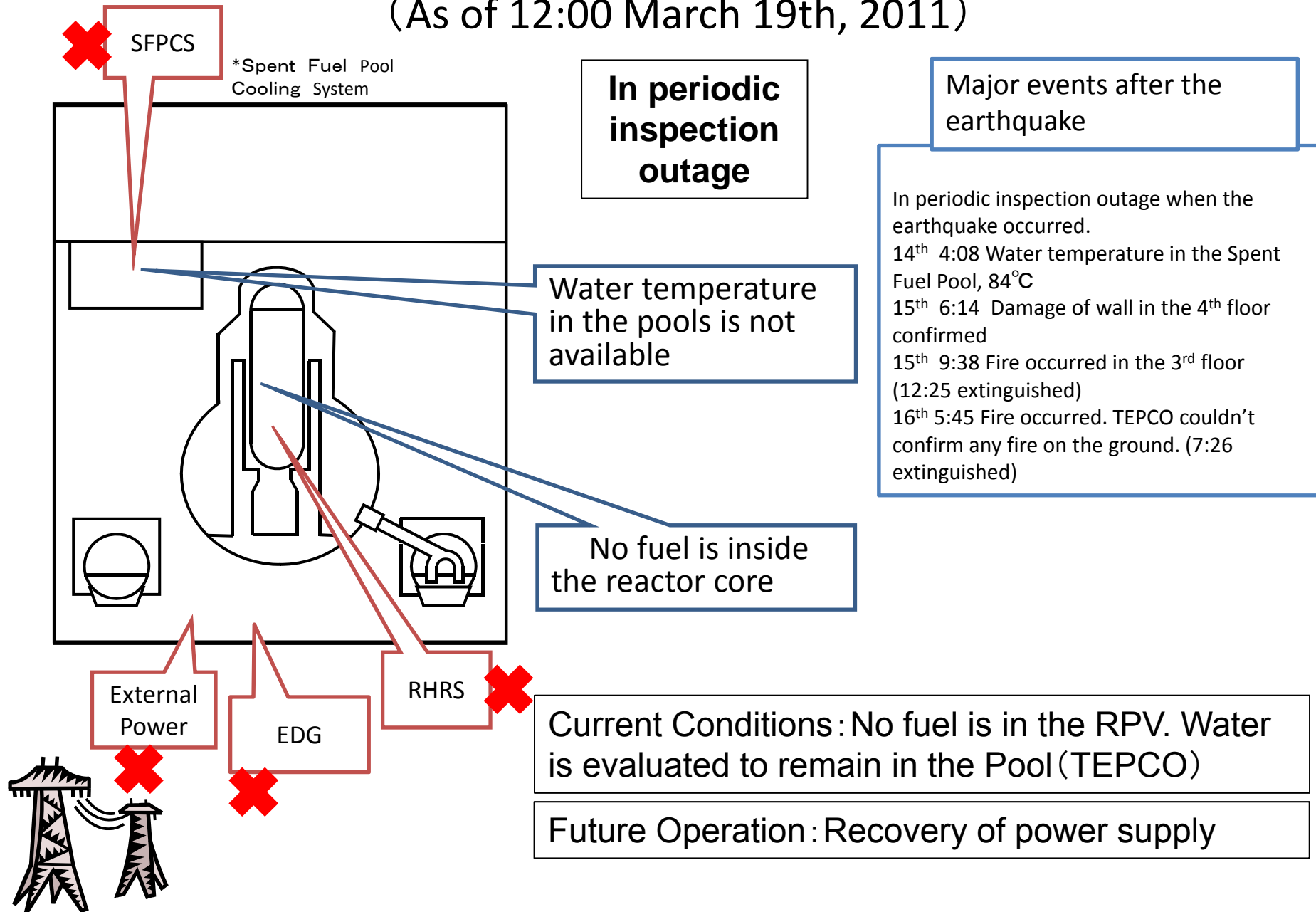

# Conditions of Fukushima Dai-ichi Nuclear Power Stations Units 5/6 (As of 12:00 March 19th, 2011)

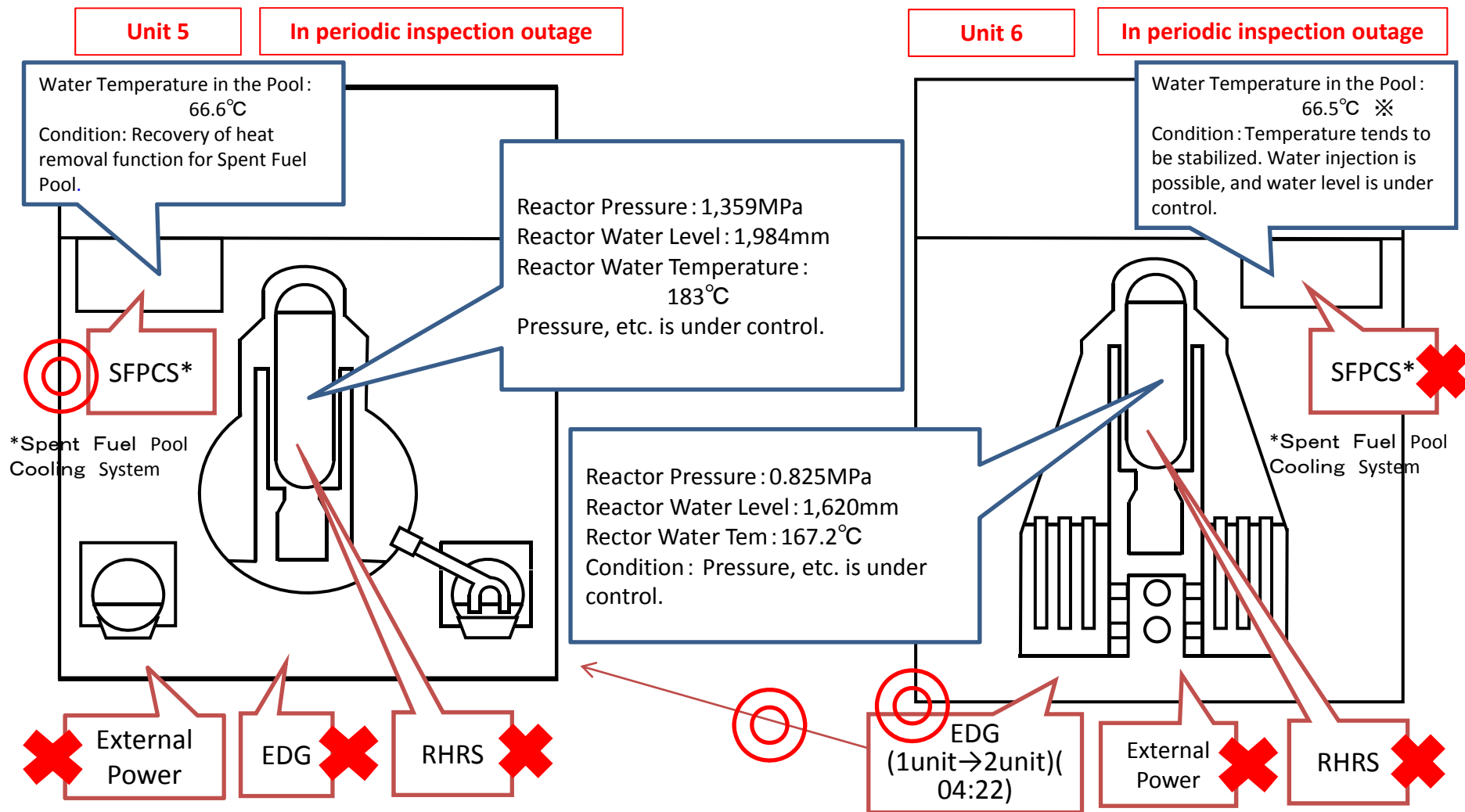

Current Conditions: Emergency Diesel Generator (1 unit →2 units (19<sup>th</sup> 04:22)) for Unit 6 is being operated. (supplying electricity to Units 5 and 6) Pump of RHR for Unit 5 started up (19<sup>th</sup> 05:00).

Future Operation: Start operating for recovery of external power